

ENHANCED DASHER™ LP2 and TP2 PRINTERS USER'S MANUAL

Models 6190-6194, 9610-9613



Ordering No. 014-000679-01

 Data General

TECHNICAL SPECIFICATIONS

General

Print Rate	180 characters per second (logic seeking, bidirectional)
Print Method	Serial 9-wire, impact through ribbon
Character Style	7 × 9 dot matrix
Character Size	Height: 2.67mm (0.105") Width: 1.93mm (0.076") (normal width characters)
Character Fonts	American, British, Danish, French, German, Spanish and Swedish
Paper Forms	Pin-feed, fan-fold, 1 to 6 parts. Width: 10.2cm to 38.1 cm (4" to 15") Hole spacing: 1.27cm (0.5") centers (nom.) Maximum form thickness: 0.625mm (0.025") Form weight: 5.45kg (12 lbs.) paper 3.63kg (8 lbs.) carbon Form crimps: tab type only
Ribbon:	Fabric ribbon, cartridge type, continuous loop.

Electrical

Parallel Interface (LP2 Printers)	Compatible with 8-bit line printer interfaces which include STROBE, DEMAND, and READY signals.
Serial Interface (TP2 Printers)	Plug compatible with either 20mA current loop or EIA RS-232C voltage interface. Available with MODEM interface.
Power Requirements	120, 220/240 volts ac (nom.), 47 to 63 Hz.
Power Dissipation	Idle: 140 Watts (typical) Running: 300 Watts (typical)
Power Cable:	1.8m (6 ft.)
External I/O Cables (max. length)	Parallel interface: 7.4 meters (25 feet) Serial interface: 20mA — 457 meters (1,500 feet) EIA — 7.6 meters (50 feet)

Mechanical

Dimensions	Height: 85.7cm (33.75") Depth: 53.3cm (21") Width: 67.3cm (26.5")
Weight:	27kg (60 lbs.)

Electro-Mechanical

Printhead Drive	Lead screw driven by permanent magnet stepping motor.
Print Wire	Pulse Width: 400 microseconds
Solenoid Drive	Actuating voltage: 48 VDC (primary) 12 VDC (secondary) Solenoid Current: 4 Amps (max.)
Ribbon Drive	Cable drive; bidirectional input, unidirectional output clutch box
Paper Feed Drive	Pin-feed tractors driven by permanent magnet stepping motor and timing belt, eight 7.5 deg steps per line at 6 lines per inch spacing.

Environmental

Temperature Ranges	Operating: 10 degC to 40 degC (50 degF to 104 degF) Storage: -40 degC to 60 degC (-40 degF to 140 degF)
Humidity Ranges	Operating: 10% to 90% (non-condensing) Storage: 5% to 95% (non-condensing)
Maximum Altitude	15,250 meters (50,000 ft.)

**ENHANCED
DASHER™ LP2 AND TP2
PRINTERS
User's Manual
MODELS 6190-6194, 9610-9613**

PREFACE

This manual is a guide to installing and using your DASHER™ LP2 or TP2 Printer. It covers programming, interfacing and cabling, installation, and architecture. For information about operating your printer, see the DASHER™ LP2 and TP2 Printers Operator's Manual, No. 014-000678.

NOTE

Similar information for the LP2/TP2 Printer, Models 6073 through 6077 may be found in the DASHER™ LP2 and TP2 Printers User's Manual, DGC part no. 014-000094 and in the Operator's Manual, DGC part no. 014-000093.

NOTICE

Data General Corporation (DGC) has prepared this document for use by DGC personnel, customers, and prospective customers. The information contained herein shall not be reproduced in whole or in part without DGC's prior written approval.

DGC reserves the right to make changes in specifications and other information contained in this document without prior notice, and the reader should in all cases consult DGC to determine whether any such changes have been made.

THE TERMS AND CONDITIONS GOVERNING THE SALE OF DGC HARDWARE PRODUCTS AND THE LICENSING OF DGC SOFTWARE CONSIST SOLELY OF THOSE SET FORTH IN THE WRITTEN CONTRACTS BETWEEN DGC AND ITS CUSTOMERS. NO REPRESENTATION OR OTHER AFFIRMATION OF FACT CONTAINED IN THIS DOCUMENT INCLUDING BUT NOT LIMITED TO STATEMENTS REGARDING CAPACITY, RESPONSE-TIME PERFORMANCE, SUITABILITY FOR USE OR PERFORMANCE OF PRODUCTS DESCRIBED HEREIN SHALL BE DEEMED TO BE A WARRANTY BY DGC FOR ANY PURPOSE, OR GIVE RISE TO ANY LIABILITY OF DGC WHATSOEVER.

IN NO EVENT SHALL DGC BE LIABLE FOR ANY INCIDENTAL, INDIRECT, SPECIAL OR CONSEQUENTIAL DAMAGES WHATSOEVER (INCLUDING BUT NOT LIMITED TO LOST PROFITS) ARISING OUT OF OR RELATED TO THIS DOCUMENT OR THE INFORMATION CONTAINED IN IT, EVEN IF DGC HAS BEEN ADVISED, KNEW OR SHOULD HAVE KNOWN OF THE POSSIBILITY OF SUCH DAMAGES."

"NOVA, INFOS, and ECLIPSE are registered trademarks of Data General Corporation, and AZ-TEXT, DASHER, DG/L, ECLIPSE MV/8000, microNOVA, PROXI, REV-UP, SWAT, XODIAC, GENAP, MAIL-CRAFT, TRENDVIEW, MANAP, and WORD-CRAFT are trademarks of Data General Corporation."

FIRST EDITION

(First Printing, April 1981)

Ordering No. 014-000679
© Data General Corporation, 1981
All Rights Reserved
Printed in the United States of America
Rev. 01, July, 1981

CONTENTS

CHAPTER I

1
1
3

INTRODUCTION

PRODUCT OVERVIEW
STANDARD PRINTER FEATURES
Optional Features

CHAPTER II

1
1
1
2
3
3
3
4
4
4
4
4
4
6
7
7
7
8
10
11
12

PROGRAMMING

INTRODUCTION
CODE RECEPTION
Printing Character Codes
Control Codes
Escape Sequences
Horizontal Tabs
Vertical Tabs
Elongated Printing
Underscoring
Resetting the Printer (Master Reset)
Compressed Printing

PLOTTING

An Example

DOWN-LINE-LOADING A CHARACTER SET

Character Sets
Defining a Character Set
Loading A Character Set

An Example

Selecting Your Character Set

SUMMARY OF PROGRAMMING RULES

CONTENTS CONTINUED

CHAPTER III

1
1
1
2
2
3
3
4

CHAPTER IV

1
2
3
3
5
6
7
7
7
8
11
11
11
11
11
11
11
11
12

INTERFACING AND CABLING

LP2-TP2 INTERFACING

Parallel Interface

Serial Interface

Printer Busy Signal

MODEM Control Signals

CABLING

Parallel Interface I/O Cables

Serial Interface I/O Cables

INSTALLATION

CHOOSING A SITE

UNPACKING

CONFIGURATION PROCEDURES

TP2 CONFIGURATION OPTIONS

CONFIGURATION GUIDELINES

LP2 Jumper/Switch Option Descriptions

LP2 Configuration Guidelines

OPERATIONAL CHECK-OUT

Offline Check-out

Online Check-out

FAULT DETECTORS

Power Line Circuit Breaker

RDY (Ready) Light

FAULT Light

Fault Indicator Board

Self Test Failure Faults

Operational Faults

Operational Fault Recovery

CHAPTER V

1
1
1
2
3
3
3
4
4
5
5
5
5
6
6
6
6
6

ARCHITECTURE

INTRODUCTION

THE MICROPROCESSOR

MEMORY

PRINthead AND CARRIAGE ASSEMBLY

The Printhead

The Carriage

Position Transducers

PAPER FEED ASSEMBLY

Sensing Paper Movement

PRINTER CONTROL PANELS

Primary Control Panel

Secondary Control Panel

KEYBOARD AND NUMERIC PAD

THE PARALLEL INTERFACE

SERIAL INTERFACE

Reception

Transmission

POWER SUPPLY

APPENDIX A

ASCII - 128 CHARACTER CODES

APPENDIX B

INTERNATIONAL CHARACTER SETS



DASHER™ LP2 AND TP2 PRINTERS

CHAPTER I

INTRODUCTION

PRODUCT OVERVIEW

The DASHER™ LP2 and TP2 family of printers are impact dot matrix printers developed for use as computer consoles, data entry terminals, hard copy printers and other similar applications.

All DASHER™ printers are capable of printing at speeds of up to 180 characters per second. Printing is bidirectional and incorporates a "logic seeking" algorithm. This algorithm determines the shortest route to a character, reducing the time that would normally be spent performing unnecessary carriage returns.

The printing mechanism contains a nine-wire printhead which forms 7 × 9 dot-matrix characters. A leadscrew assembly moves the printhead to ensure precise printhead positioning. Movable, pin-feed tractors accommodate 1 to 6 part forms ranging from 4 to 15 inches in width.

The printers are equipped with either a parallel or serial interface. DASHER LP2 printers are equipped with a parallel interface which allows you to attach them to a system in place of a line printer. DASHER TP2 printers are equipped with a serial interface which allows you to attach them to an asynchronous communications line. Both EIA RS-232C or 20mA current loop connections are provided on serial interface models. In addition, these models may be used in conjunction with Bell 103 and 212A compatible MODEMs.

STANDARD PRINTER FEATURES

All members of the printer family include the following features:

- International character fonts
- Horizontal and vertical tabbing
- Plotting
- Underscoring
- Elongated printing
- 6 or 8 lines/inch spacing
- Automatic form feed
- Down line loaded character set
- Compressed printing
- Alternate character sets

International Character Fonts — All members of the printer family may be configured to use two of the following seven international character fonts:

- American
- British
- French
- German
- Swedish
- Danish
- Spanish

Any two of these fonts may be configured as standard and alternate character sets.

DASHER MODEL CONFIGURATIONS

MODEL	TYPE	DESCRIPTION
6190	LP	Receive only line printer with parallel interface
6191	LP	Receive only line printer subsystem, parallel interface, Nova/Eclipse programmed I/O controller, paper holder.
6192	LP	Receive only line printer subsystem parallel interface, Nova/Eclipse data channel controller, paper holder
6193	TP	Receive only terminal printer with serial interface
6194	TP	Keyboard send/receive terminal printer with serial interface
9610	LP	Receive only line printer subsystem with parallel interface for CS/10 C1 systems
9611	LP	Receive only line printer subsystem with parallel interface for use with CS/10 C3 systems
9612	LP	6190 Receive only printer with parallel interface configured for CS/30 systems
9613	LP	6190 receive only line printer with parallel interface configured for CS/40+ systems
1285A	—	Box of 12 ribbon cartridges for all models
1285B	—	Box of 60 ribbon cartridges for all models
1285C	—	Box of 600 ribbon cartridges for all models
1127A	—	Paper holder for all models

NOTE

All models are equipped with all international character sets; however only two sets may be used at any give time (primary and secondary sets) as selected by SW1 on the Control Logic PWB. The primary set is configured according to the beta suffix to the model number and the secondary set is always configured as the U.S. character set (can be reconfigured to any desired set during installation).

Standard Features CONTINUED

Horizontal Tabbing - permits user to set or clear tabs anywhere in the 132 character line (220 character line is compressed print mode). All tabs may be set with a single escape sequence as described in the Programming Chapter.

Vertical Tabbing - Allows you to move quickly to any line in your form. You can set all the vertical tabs for a form using just one escape sequence.

Plotting - Allows you complete control over 7 of the 9 individual print wires. The 7-bit codes received by your printer directly determine which of these seven printhead wires will fire to form a particular column. While in plot mode, there is no interline spacing so you can print continuous graphs.

6 or 8 Lines/Inch - Allows you to select the interline spacing you want on your form. The selection is made by a switch located on the Secondary Control Panel.

Elongated Printing - Allows you to print characters at twice the width of normal characters (normal = 10 characters/inch; elongated = 5 characters/inch). You can switch to elongated printing at any time for as long as you like.

Underscoring - Allows you to underline characters, strings, or complete lines. The underscore is printed at the same time as the character so your printer doesn't waste time scanning a line twice to fill in the underscores.

Down Line Loaded Character Set - Allows your system to load a character set into your printer. You may design your own character set with up to 118 printable characters.

Alternate Character Set - This feature permits the user to print characters from a second character set. This second character set may be one of the seven international character fonts or an optional character set depending on the setting of the Control Logic PCB configuration switches (see Install chapter for additional detail).

Automatic Form Feed - Allows you to advance the paper to the top of the next form in one operation. Included is the automatic perforation skip-over feature which allows you to skip the perforation between forms.

Compressed Print - Allows you to print 132/220 characters/line on 8½/14-inch wide paper.

Optional Features

Parallel Interface - Allows you to connect your printer to systems equipped with a parallel ASCII line-printer interface. The parallel interface transfers 7 or 8 bits of information at a time. In addition, it sends signals which inform the system when the printer is powered-up and online as well as when the printer's buffer can accept characters.

Serial Interface - Allows you to connect your printer to asynchronous communications equipment. This interface transfers a serial data stream in either direction between your printer and a communications system. The interface has eight different transfer rates from 110 to 4800 baud. In addition, there are a number of switch selectable data formats.

NOVA/ECLIPSE Programmed I/O Controller - Allows you to connect your printer to a Data General system previously without a line printer interface. The controller communicates with a NOVA or ECLIPSE CPU via programmed I/O instructions. It resides on a 15-inch square circuit board which plugs into any I/O slot of a NOVA or ECLIPSE computer chassis.

NOVA/ECLIPSE Data Channel Controller - Allows you to connect your printer to a Data General system previously without a line printer interface. The controller communicates with a NOVA or ECLIPSE CPU via the data channel. It resides on a 15-inch square circuit board which plugs into any I/O slot of a NOVA or ECLIPSE computer chassis.

Ribbon Cartridges - Replacement fabric-type, continuous-feed ribbon cartridges for use on all model printers.

Paper Holder - Collects and stacks fan-fold style forms from your printer.

	CHARACTERS PER INCH	
	REGULAR	ELONGATED
Normal	10	5
Compressed	16.5	8.25

EXAMPLES OF PRINT SPACING

This is an example of the DASHER LP2 and TP2 printers' capabilities. The text you are reading is printed using normal width characters at 6 lines per inch vertical spacing.

This is an example of the DASHER LP2 and TP2 printers' capabilities. The text you are reading is printed using normal width characters at 8 lines per inch vertical spacing.

This is an example of the DASHER LP2 and TP2 printers' capabilities. The text you are reading is printed using elongated width characters at 6 lines per inch vertical spacing.

This is an example of the DASHER LP2 and TP2 printers' capabilities. The text you are reading is printed using elongated width characters at 8 lines per inch vertical spacing.

This is an example of the DASHER LP2 and TP2 printers' capabilities. The text you are reading is printed using compressed width characters at 6 lines per inch vertical spacing.

This is an example of the DASHER LP2 and TP2 printers' capabilities. The text you are reading is printed using compressed width characters at 8 lines per inch vertical spacing.

This is an example of the DASHER LP2 and TP2 printers' capabilities. The text you are reading is printed using compressed elongated width characters at 6 lines per inch vertical spacing.

This is an example of the DASHER LP2 and TP2 printers' capabilities. The text you are reading is printed using compressed elongated width characters at 8 lines per inch vertical spacing.

Compressed print underscored

Regular print underscored

Compressed elongated print underscored

Elongated print underscored

INTERNATIONAL CHARACTER SET EXAMPLES

These are the character sets available on DASHER LP2 and TP2 printers.

The U. S. character set is:
ABCDEFGHIJKLMNOPQRSTUVWXYZ
abcdefghijklmnopqrstuvwxyz
1234567890!@#%&*()-_+=~`[]\|;:'"<>, <.>/?

The U. K. character set is:
ABCDEFGHIJKLMNOPQRSTUVWXYZ
abcdefghijklmnopqrstuvwxyz
1234567890!@#%&*()-_+=~`[]\|;:'"<>, <.>/?

The FRENCH character set is:
ABCDEFGHIJKLMNOPQRSTUVWXYZ
abcdefghijklmnopqrstuvwxyz
1234567890!@#%&*()-_+=~`*§çù;:'"èé, <.>/?

The GERMAN character set is:
ABCDEFGHIJKLMNOPQRSTUVWXYZ
abcdefghijklmnopqrstuvwxyz
1234567890!@#%&*()-_+=~`βäüö;:'"äü, <.>/?

The SPANISH character set is:
ABCDEFGHIJKLMNOPQRSTUVWXYZ
abcdefghijklmnopqrstuvwxyz
1234567890!@#%&*()-_+=~`[]ñ;:'"<>, <.>/?

The SWEDISH character set is:
ABCDEFGHIJKLMNOPQRSTUVWXYZ
abcdefghijklmnopqrstuvwxyz
1234567890!@#%&*()-_+=~`öåäö;:'"äå, <.>/?

The DANISH character set is:
ABCDEFGHIJKLMNOPQRSTUVWXYZ
abcdefghijklmnopqrstuvwxyz
1234567890!@#%&*()-_+=~`åäö;:'"zå, <.>/?

DATA GENERAL CORP.
Austin, TX

This page intentionally left blank.

CHAPTER II

PROGRAMMING

INTRODUCTION

Your DASHER printer receives information from a computer or communications line. DASHER TP2 printers can transmit as well as receive information. This information is represented by 7-bit ASCII codes. The 128 characters in the standard ASCII set consist of 96 upper and lower case alphanumeric, punctuation, and graphic characters as well as 32 control codes. If your printer receives an alphanumeric code, it prints the corresponding character. If it receives a valid control code, it performs the specific function defined by the code. If, however, your printer receives one of the control codes it does not use, it ignores that code.

CODE RECEPTION

Your printer can store up to 2528 characters in its buffer. Characters enter the buffer from either a parallel interface (DASHER LP2 Printers) or a serial interface (DASHER TP2 Printers). Both types of interfaces are able to signal the computer or communications system that the buffer is full.

The parallel interface controls a special hardware signal which tells the computer system when there is room in the buffer for a character. This is consistent with most line printer interfaces. As a result, the programmer need not worry about overflowing the buffer when programming a DASHER LP2 printer.

The serial interface is equipped with two methods of preventing the buffer from overflowing. It can tell the communications system to stop transmitting data via a hardware signal (for local connections), by transmitting special control characters (full duplex). Chapter III discusses how these particular methods are used.

While receiving codes, the printer scans those codes already in the buffer to determine the fastest way to print each line. If the buffer becomes filled, the printer uses one of the methods discussed above to stop the system from transmitting codes. As soon as there is room in the buffer, the printer can accept additional codes.

Your printer responds to three types of information:

- Printing Character Codes - which result in a character being printed.
- Control Codes - single codes which control special functions.
- Escape Sequences - sequences of codes (beginning with an escape) which control certain functions.

The table in Appendix A provides a concise summary of the ASCII codes, their octal and decimal values, and how a DASHER printer responds to them.

Printing Character Codes

The printing characters include all the upper and lower case alphanumeric characters as well as graphic, punctuation, and space characters. Up to 132 characters may be printed on each line (220 characters in compressed mode). If more than 132 characters (220 in compressed mode) are received without a line terminator, they are not printed. New lines (012 octal), vertical tabs (013 octal), form feed (014 octal) and carriage returns (015 octal) are all considered line terminators.

Control Codes

Your printer recognizes a number of control codes it receives as commands to perform specific operations. In addition to recognizing control codes, DASHER TP2 printers can transmit a number of control codes. The control codes and their effects are listed in the accompanying table.

DASHER LP2 AND TP2 PRINTER CONTROL CODES

NAME	MNEMONIC	CONTROL CODE (OCTAL)	EFFECT
(Codes received)			
Bell	BEL	0 0 7	Sounds audible tone immediately after code is received.
Back Space	BS	0 1 0	Print head moves back one character position.
Horizontal Tab	HT	0 1 1	Print head moves to next horizontal tab stop. If no tab is set, the command is ignored.
Newline (Line Feed)	NL	0 1 2	Terminates the present line, advances the paper one line, and either: a) determines the fastest way to print the next line (if it is complete), or b) performs a carriage return and prints any characters from left to right.
Vertical Tab	VT	0 1 3	Paper advances to next tab stop. If no tab is set, the command is ignored.
Form Feed	FF	0 1 4	Paper advances to the top of the next form.
Carriage Return	CR	0 1 5	Carriage returns to the left-hand margin.
Shift Out	SO	0 1 6	Selects alternate character set.
Shift In	SI	0 1 7	Selects standard character set.
Escape	ESC	0 3 3	Denotes the beginning of a command sequence.
(Codes transmitted)*			
Device Code 1	DC1	0 2 1	** Indicates that the character buffer has room for more characters.
Device Code 3	DC3	0 2 3	** Indicates that the character buffer is full.

*On DASHER TP2 printers only.

**When Software Busy is enabled (See Installation Chapter).

Escape Sequences

A number of functions on your printer may be controlled by special sequences of codes called escape sequences.

- Horizontal and vertical tabbing
- Elongated characters
- Underscoring
- Plotting
- Resetting the printer
- Compressed printing
- Down line loading a character set

An Escape code (033₈), if enabled, defines the beginning of these sequences while subsequent codes define the particular function to be performed. If no valid code follows the Escape code, the Escape code is ignored and subsequent codes produce the standard effect. If the Escape disable switch on the secondary control panel is in the disable position, all escape codes are ignored and subsequent codes are printed.

Horizontal Tabs

You may set a horizontal tab anywhere from the second to the last (220th) character position. The printhead advances to the next horizontal tab stop following the reception of a Horizontal Tab (CTRL-I) control code (011₈) and at least one printing character code. If you haven't set any horizontal tabs and CTRL-I is received, the command has no effect. The following escape sequences set and clear horizontal tabs:

ESCAPE SEQUENCE (OCTAL CODES)	EFFECT ON PRINTER
ESC 1 (033 061)	Sets a horizontal tab at the current printhead position.
ESC 2 (033 062)	Clears a horizontal tab from the current printhead position.
ESC E # # ... NULL (033 105 # ... 000)	Sets horizontal tabs at each character position specified by an octal number (#). A tab may be set anywhere from the second character position (# = 002 ₈) to the last character position (# = 334 ₈ = 220 ₁₀)*. All previously set horizontal tabs are cleared.
ESC E NULL (033 105 000)	Clears all horizontal tabs.

* See Appendix A for decimal/octal equivalents.

Note: If your computer or communications system only supplies 7 data bits to the printer, you should use the ESC 1 sequence to set horizontal tabs. The ESC E sequence will only be able to set tabs to the 127th column position.

Vertical Tabs

You may set a vertical tab anywhere from top of a form to the line preceding the top of the next form. The printer keeps track of the number of lines per form and the user's current line position. However if you have perforation skip-over enabled (see Operator's Manual), you must remember that you have, in effect, fewer lines per form.

When a printer receives a Vertical Tab (CTRL-K) control code (013 octal), it advances the paper to the beginning of the next line on which a vertical tab is set. If no vertical tab is set, Vertical Tab code acts like a Carriage Return. The following escape sequences are used to set and clear vertical tabs:

NOTE: Tabs may be set or cleared only after a line terminator has been received.

ESCAPE SEQUENCE (OCTAL CODE)	EFFECT ON PRINTER
ESC 5 (033 065)	Sets a vertical tab at the current line position.
ESC 6 (033 066)	Clears a vertical tab from the current line position.
ESC F # # ... NULL (033 106 # # ... 000)	Sets a vertical tab at the positions specified by the octal numbers (#). These numbers may be anywhere from 1 to the maximum line length of the form you are using (no form can be more than 99 lines long). All previously set vertical tabs are cleared.
ESC F NULL (033 106 000)	Clears all vertical tabs.

Elongated Printing

You can print elongated (double width) characters in either the normal mode or the compressed mode. Elongated characters may be selected anywhere within a line. You should note that only 66 elongated characters will fit on a regular 132-character line. You can mix normal and elongated characters in a single line, but you must keep in mind that elongated characters are twice the width of normal characters. The escape sequences which control this feature are given below:

ESCAPE SEQUENCE (OCTAL CODE)	EFFECT ON PRINTER
ESC < (033 074)	Selects elongated printing for subsequent characters.
ESC = (033 075)	Deselects elongated printing.

Underscoring

You may underscore characters, words, or complete lines by turning the underscore feature on and off. The underscore is printed at the same time as the character. Normal width and elongated characters may be underscored in both the Normal and the Compressed printing modes. You enable and disable underscoring as follows:

ESCAPE SEQUENCE (OCTAL CODE)	EFFECT ON PRINTER
ESC a (033 141)	Starts underscoring. Subsequent print positions are underscored until the command sequence turning off the feature is received.
ESC b (033 142)	Stops underscoring. Subsequent print positions are not underscored.

Resetting the Printer (Master Reset)

A software Master Reset (ESC c NULL; 033₈ 143₈ 000₈ 000₈) allows you to reset and reinitialize your printer according to the settings of the secondary control panel. In addition, it clears the character buffer, clears any horizontal or vertical tabs, turns off underscoring and turns off elongated printing.

Compressed Printing

Your printer allows you to print either normal or compressed width characters. While in the normal mode, you can print 132 normal width characters on regular 132-column paper. In compressed mode, you can print 220 compressed characters on 132-column paper. However, you may issue the escape sequences to change the print mode only after a line terminator, i.e., Newline (012₈), Vertical Tab (013₈), Form Feed (014₈), or Carriage Return (015₈). Both escape sequences are ignored unless they are issued at the proper time. These escape sequences are given below:

ESCAPE SEQUENCE (OCTAL CODE)	EFFECT ON PRINTER
ESC > (033 076)	Switches the printer from normal printing to the compressed printing mode.
ESC ? (033 077)	Switches the printer back from the compressed printing mode to normal mode.

PLOTTING

Plotting is a standard feature on all model printers. In plot mode, 7 of the printhead's 9 firing wires, (the bottom 7 wires) are under the user's direct control. The seven wires print in vertical columns. Each column is printed separately. Your printer plots from left to right at 900 columns per second. You may plot up to 1320 columns per line. (2200 columns in compressed mode.)

To plot, you enter plot mode and send a 7-bit code (from 0 to 177) to your printer. Instead of interpreting these 7-bits as an ASCII code and printing the corresponding 7-column character, the printer interprets the code as a command to print one column. Each bit of the code determines if a particular wire will be fired. The relationship between a seven bit code and the printhead wires which are fired is shown in the accompanying illustration. A "1" in a bit position fires the corresponding print-wire.

You enter plot mode by issuing a line terminator, i.e., Newline (012₈), Vertical Tab (013₈), Form Feed (014₈), or Carriage Return (015₈), followed by ESCape d (033₈ 144₈). This escape sequence must be issued after a line terminator; otherwise it will be ignored. After

entering plot mode, you issue the series of 7-bit codes which define the columns you wish to plot. These columns WILL NOT be plotted until after you terminate the current line. To terminate a line, you must deselect plot mode (issue an ESC e: 033_o, 145_g) and issue a line terminator. If the next line is to be plotted, issue a Newline (012_g) after deselecting plot mode. The printer will produce a line feed with NO interline spacing. However, inserting any terminator between the plot deselect sequence and the Newline code causes the printer to produce normal (6 or 8 lpi) interline spacing. To plot another line, enter plot mode, issue the codes to be plotted, exit plot mode, and issue a line terminator.

To plot ESCape (033 Octal), you must transmit it twice in a row (since it could signal the beginning of the deselect sequence). Do not issue any other escape sequences while the printer is in plot mode.

If you are in normal mode when you enter plot mode, the printer plots with the same spacing between columns as normal width characters. However, if you are in compressed mode, the printer plots with the same spacing as compressed characters.

ESCAPE SEQUENCE (Octal Code)	EFFECT ON PRINTER
ESC d (033 144)	Selects plot mode.
ESC e (033 145)	Deselects plot mode.

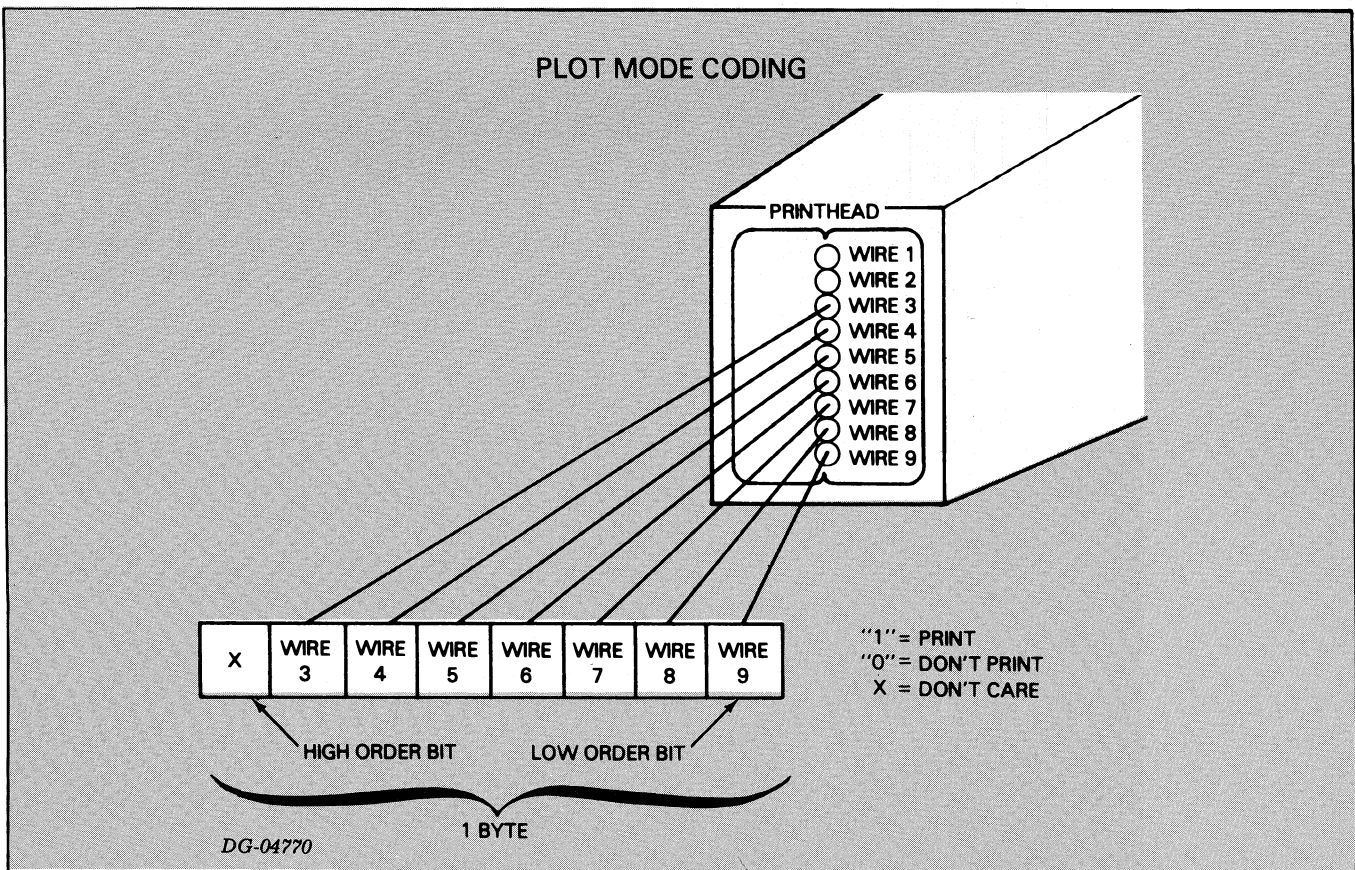

An Example

Suppose you wanted to plot a 14 by 14 dot matrix square at the left hand margin. You must determine the codes you need and the order in which to send them. The codes for the square we want to make are shown below.

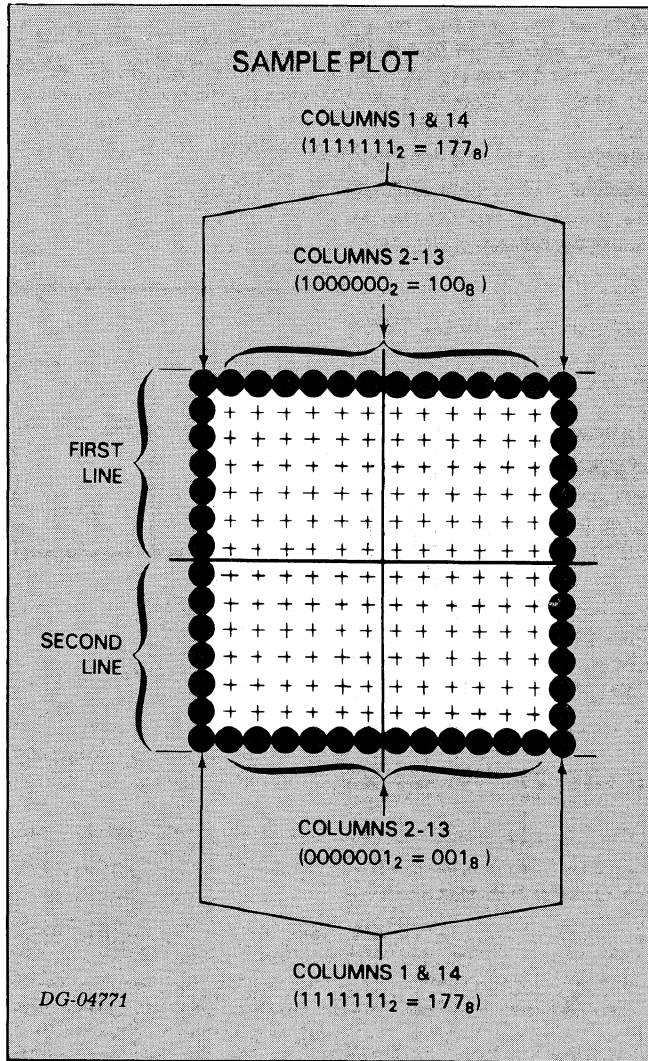

The sequence you would use to plot this square is:

OCTAL CODE	EFFECT
012	Newline
033	Enter plot
144	mode
177	Prints column 1, first line
100 (12 times)	Prints columns 2-13, first line
177	Prints column 14, first line
033	Exit
145	Plot Mode
012	Newline
033	Enter
144	Plot Mode
177	Prints column 1, second line
001 (12 times)	Prints columns 2-13, second line
177	Prints column 14, second line
033	Exit Plot
145	Mode
012	Newline

The image which results from this plot sequence is more of a rectangle than a square because successive horizontal print positions overlap.

DOWN-LINE-LOADING A CHARACTER SET

DASHER printers allow you to define your own character set. You can define a character set which prints up to 118 7×9 dot matrix characters. Once you have defined each character in your character set, you load the set into the printer's memory via an escape sequence. Two additional escape sequences allow you to select and deselect the character set.

The Down-Line-Load Character Set feature is very handy if you want to design your own character set or if you must be able to print in a number of different character fonts. When the printer is powered down or a Master Reset is performed, a down-line-loaded character set must be reloaded.

NOTE *Your computer or communications system must be set up to transmit 8 data bits at a time in order to down line load and select a character set.*

Character Sets

Your printer accepts up to 127 different 7 bit character codes. By convention, the first 32 codes (0-37₈) are control codes which do not print any characters. The remaining 95 characters (40₈ - 176₈) are printing characters.

When you down line load a character set, you may define any printing character except for control codes which perform specific functions on LP2 and TP2 printers. These codes include 7₈ - 17₈, and 33₈. The functions of these codes are summarized in the table entitled DASHER LP2 and TP2 Printer Control Codes (page II-2). Therefore, a down line loaded character set can define 118 individual characters. The codes for which characters may be defined include 0 - 6₈, 20₈ - 32₈, and 34₈ - 177₈.

Defining A Character Set

Each dot pattern in a character set is defined using a 7×9 dot matrix. The following diagram shows the relative print-wire locations and column positions available to form one character. Information on how characters are actually printed may be found in Chapter V.

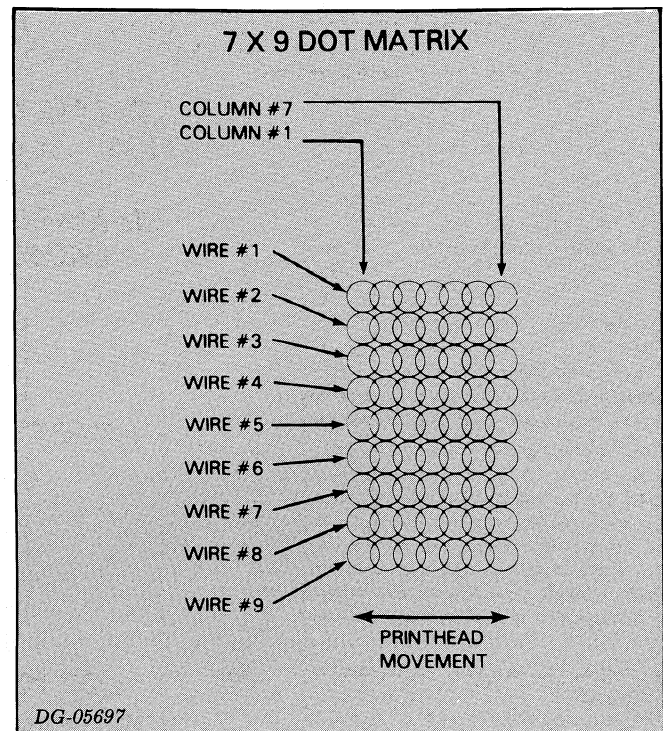

You select the dots to be printed via the seven 9-bit firing codes. A "1" in the firing code indicates that the corresponding wire will be fired when that column is printed. A "0" in the firing code indicates that the corresponding wire will not be fired. The one restriction in selecting firing codes is that print wires may not be consecutively fired (i.e., the same bit may not be a "1" in two successive firing codes).

Once the firing codes for a character are determined, they must be put into a format which allows them to be loaded into the printer. The printer uses eight memory locations to store one character. The first memory location MUST contain all zeros. The following seven memory locations each contain one 9-bit firing code that determines which of the 9 wires in the printhead will fire to form one column of a character. A character's firing codes are ordered in memory with the first column in the lowest memory location and the seventh column seven locations above the first. For example, the firing codes for the character "B" would be organized as shown in the following diagram:

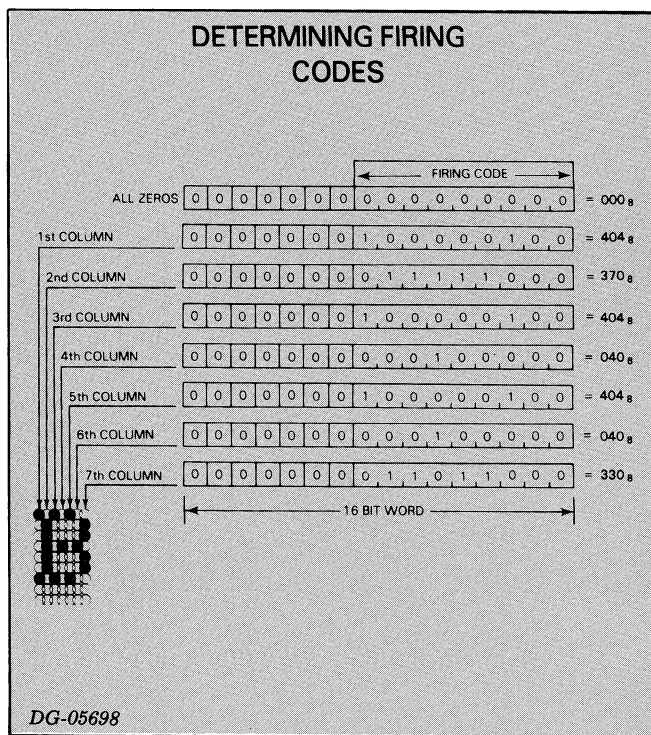

Loading A Character Set

In order to understand the format used in downloading a character set it is useful to visualize the printer memory as 4000₈ 16 bit wide words. The downloaded character set begins at word 2000₈ and extends to word 3777₈. This allows a character set storage area of 2000₈ words (4000₈-2000₈ = 2000₈). Each character requires

10₈ words of storage; so the 2000₈ words in the character set storage area can store 200₈ or 128₁₀ characters. The Starting Character Set Address (SCSA) is always 2000₈ because the character set storage area begins at word 2000₈.

The location of the downloaded dot pattern in the character set storage area determines which ASCII code will print that dot pattern. ASCII code 000₈ prints the first dot pattern in the character set storage area. This pattern occupies the 10₈ words from 2000₈ to 2007₈. Likewise ASCII code 001₈ will print the dot pattern beginning at word 2010₈ ending with word 2017₈. This suggests a formula for determining which locations should contain the dot pattern printed by any ASCII code:

$$\text{Starting Word Address} = 2000_8 + (\text{ASCII code}_8 \times 10_8)$$

The Starting Word Address in the formula is the address containing the first word in the ASCII code's dot pattern. The other 7 words in the dot pattern follow in the next 7 addresses. Using the formula the addresses for the last dot pattern (corresponding to ASCII code 177₈) can be found.

$$\begin{aligned} \text{Starting Word Address} &= 2000_8 + (177_8 \times 10_8) \\ &= 2000_8 + 1770_8 \\ &= 3770_8 \end{aligned}$$

So the last dot pattern resides in words 3770₈ - 3777₈. This is the very top of the character set storage area.

When downloading a dot pattern into memory, the user defines which ASCII code prints that pattern by specifying the correct starting address for the load. More detail on this below.

Users need not download character sets one dot pattern at a time. With a single ESC Y sequence, any number of dot patterns (up to 128₁₀) may be loaded into memory. The only restriction is that the printer will load the dot patterns sequentially into memory beginning at the user's specified starting address. The user defines how many dot patterns are to be loaded during a particular ESC Y sequence by specifying the length of the data block containing the consecutive dot patterns. More detail on this will be given below.

The communication interface receiving the download character set escape sequence receives only 8 bits (one byte) at a time. Therefore dot patterns are loaded sequentially into memory one byte at a time. The dot patterns consist of 9 bit firing codes contained in 16 bit words. These 16 bit words must be broken into two 8 bit bytes before transmitting them to the printer.

CHARACTER SET ORGANIZATION IN MEMORY

STARTING WORD ADDRESS:

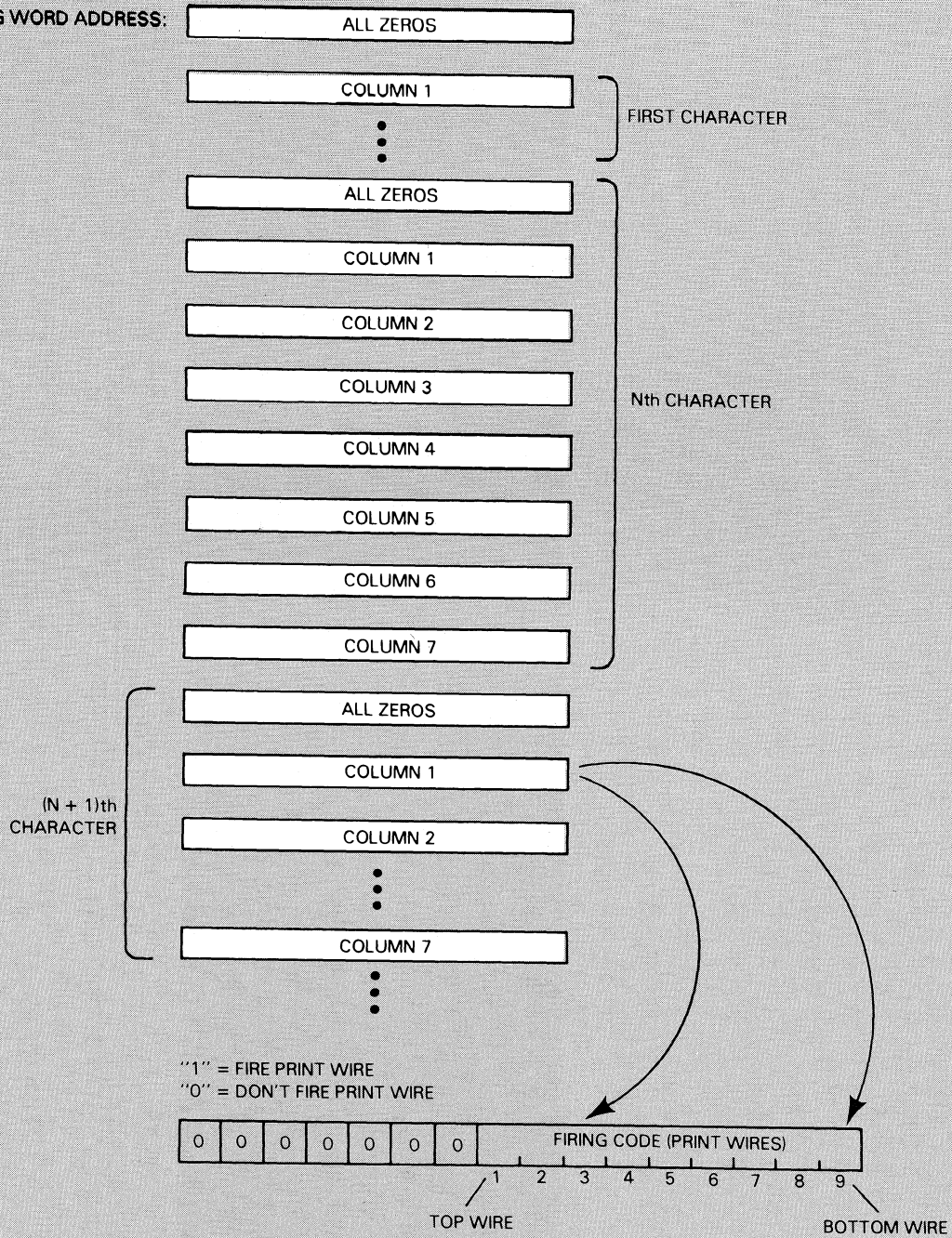

DG-05695

16 BIT WORD

/ LEFT BYTE / RIGHT BYTE /

When sending a word to the printer in two bytes, the left byte is always transmitted before the right byte.

In addition to the bytes split from the words in the dot patterns, the ESC Y sequence also transmits the following information:

- Byte Count - defines how many dot patterns are to be loaded in this ESC Y sequence by specifying the number of BYTES contained in the dot patterns.

Byte Count =

$$\begin{array}{r} \text{Number of} \\ \text{Dot Patterns} \end{array} \times \begin{array}{r} 8 \text{ words per} \\ \text{Dot Pattern} \end{array} \times \begin{array}{r} 2 \text{ bytes} \\ \text{per word} \end{array}$$

- Starting Byte Address - defines which ASCII codes print the dot patterns downloaded in this ESC Y sequence by specifying BYTE ADDRESS in the character set storage area where the first of the consecutive dot patterns begins. The STARTING BYTE ADDRESS is simply 2 times the Starting Word Address computed using the formula above or:

$$\text{Starting Byte Address} = 2 \times [2000_8 + (\text{ASCII CODE}_8 \times 10_8)]$$

- Negated Checksum - a number used by the printer at the end of the load sequence to determine if any data errors occurred during the load.

The one byte Negated Checksum is obtained by summing all the data bytes, ignoring any carry, and taking the 2's complement of that sum. This sum does not include the Byte Count or the Starting Byte Address, just the bytes containing the firing codes.

You must transmit data to a printer one byte (8-bits) at a time. You cannot load a character set if you have a DASHER TP2 printer with an interface set up to receive only 7 data bits at a time. The following table gives the escape sequence for loading a character set into an LP2 or TP2 printer.

CHARACTER SET LOADING ESCAPE SEQUENCE

ESCAPE SEQUENCE	OCTAL VALUE	NUMBER OF BYTES
ESCape	033	1 BYTE
Y	131	1 BYTE
BYTE COUNT	---	2 BYTES
STARTING BYTE ADDRESS	---	2 BYTES
DATA	---	2 BYTES
DATA	---	2 BYTES
.		
.		
DATA	---	2 BYTES
NEGATED CHECKSUM	---	1 BYTE

An Example

Suppose you want to load a printer with a character set consisting of one character, the character "B". Proceed as follows:

- 1) Determine a starting address for the load. The ASCII code for "B" is 102 (octal). The starting address for the load is computed as follows:

$$\begin{aligned} \text{ADDRESS} &= 2000_8 + (102_8 \times 10_8) \\ &= 2000_8 + 1020_8 \\ &= 3020_8 \end{aligned}$$

- 2) Calculate the starting byte address as follows:

$$\begin{aligned} \text{Starting Byte Address} &= 2 \times \text{Starting Word Address} \\ &= 2 \times 3020_8 \\ &= 6040_8 \quad \text{right byte} \\ &= \underbrace{0\ 000\ 110\ 000}_{\text{left byte}} \underbrace{100\ 000}_2 \end{aligned}$$

Divide this into two bytes, left hand byte first: 014₈
040₈

3) Calculate the Byte Count.

$$\begin{aligned}
 \text{Byte Count} &= \text{Number of Characters} \times 8 \text{ words per character} \times 2 \text{ bytes per word} \\
 &= 1 \times 8 \times 2 \\
 &= 16_{10} \\
 &= 20_8 \quad \text{right byte} \\
 &= \underbrace{0\ 000\ 000}_{\text{left byte}} \underbrace{000\ 010\ 000}_2
 \end{aligned}$$

Divide this into two bytes, left-hand byte first: 000₈ 020₈

4) Determine the data bytes and the Negated Checksum.

From the illustration "Firing Codes for the Character B" we know the 16-bit firing codes. These are broken into bytes, left-hand byte first. The 2's complement of the sum of these bytes forms the checksum byte.

16-bit code (octal)	8-bit code (octal)	byte sum
00000	000 000	000 +001
00404	001 004	001 +004
00370	000 370	005 +370
00404	001 004	375 +001
00040	000 040	376 +004
00404	001 004	402 +040
00040	000 040	442 +001
00330	000 330	443 +004
		447 +040
		507 +330
		sum = 1037
		sum (8-bits) = 037
		Negated Checksum (2's complement) = 341

Therefore, the Down-Line-Load sequence for the character set is:

- 033 Escape Sequence for Down-Line-Load initiation
- 131
- 000 Byte Count
- 020
- 014 Starting Byte Address
- 040
- 000 Firing Codes for a "B"
- 000
- 001
- 004
- 000
- 370
- 001
- 004
- 000
- 040
- 001
- 004
- 000
- 040
- 000
- 330
- 341 Negated Checksum

Selecting Your Character Set

A down-line-loaded character set is selected and deselected via escape sequences. These escape sequences are given below:

DOWN-LINE-LOAD CHARACTER SET SELECT /DESELECT

ESCAPE SEQUENCE (OCTAL)	FUNCTION
ESC N SCSA (033 116 004 000)	SELECTS A DOWN-LINE-LOADED CHARACTER SET GIVEN A STARTING CHARACTER SET ADDRESS (SCSA) of 2000 ₈ .
ESC 0 (033 117)	DESELECTS A DOWN-LINE-LOADED CHARACTER SET.

The value used for the Starting Character Set Address is always 2000₈.

SUMMARY OF PROGRAMMING RULES

The following escape sequences may be issued anywhere within a line:

- Horizontal tab set or clear at current printhead position
- Underscore on or off
- Elongated character(s) select or deselect
- Alternate character set select or deselect

- Setting and clearing of multiple horizontal tabs
- Vertical tab setting or clearing
- Downline character set load and select

The following escape sequences may be issued only after line terminator (newline, vertical tab, form feed or carriage return):

- Plot mode select
- Compressed print select or deselect

CHAPTER III

INTERFACING AND CABLING

LP2-TP2 INTERFACING

Your DASHER printer is equipped with either a parallel interface or a serial interface. The parallel interface is available on DASHER LP2 receive-only printers. The serial interface is available on DASHER TP2 receive-only and keyboard-send-receive printers.

Parallel Interface

You may connect a DASHER LP2 printer equipped with a parallel interface to any system containing a 7 or 8-bit line printer port. This interface requires seven or eight data lines and a STROBE line from the computer. In addition, a DEMAND line tells the computer when the printer wants another character while a (READY line notifies the system when the printer is powered up and online.) The electrical and timing requirements for this interface are given below:

PARALLEL INTERFACE REQUIREMENTS

SIGNAL	CHARACTERISTICS *
Data Lines	High = a logical 1. Low = a logical 0.
STROBE	Duration: 0.5 - 10 μ s Data lines are sampled on falling edge of STROBE.
DEMAND	High = Requesting Data Low = Busy
READY	High = Printer powered up and ON LINE. Low = Printer NOT READY.

* High = 2.4 - 5.0 Volts
Low = 0.0 - 0.4 Volts

Serial Interface

You may connect a DASHER TP2 printer equipped with a serial interface to a communications system via either 20mA current loop or EIA RS-232C connections. The interface receives and transmits data in serial data bursts which consist of a start bit, 7 or 8 data bits, an optional parity bit, and 1 or 2 stop bits. You select the particular data format via jumpers (see Chapter IV, Tailoring the Switches on the Control Logic PCB).

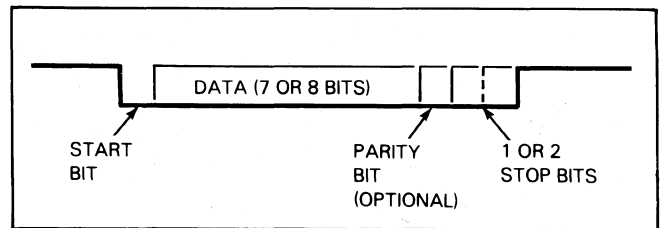

The electrical requirements for current loop connections are given in the following table:

	TERMINAL TRANSMITTING	TERMINAL RECEIVING
MARK SENSE	V max = 40V I max = 40mA	V max = 40V
SPACE SENSE	I = 10 - 60mA	I < 5mA

Printer Busy Signal

The function of a busy signal is to tell the transmitting device to stop sending data so that the printer's character buffer does not overflow (i.e., lose data). The DASHER TP2 printer's serial interface has two different methods for telling the transmitting device to stop sending information.

The first method uses a hardware busy signal provided in both EIA and current loop configurations. This method is designed for use with local connections to a processor (i.e., not through a MODEM). The signal is labeled RTS on the EIA connector (J29) and BUSY on current loop connection J28. The polarity of the hardware busy signal is switch selectable on the Control Logic PCB. The hardware busy signal is asserted when the buffer contains more than 2272 bytes. This signal notifies the controller to stop sending data because the buffer is nearly full. After the buffer drops below 512 bytes, the hardware busy signal is deasserted indicating that the controller can resume transmitting data.

The second method, called X/ON X/OFF, requires your printer to transmit one of two codes to the transmitting device, telling it to start or stop sending data. A DC2 (023₈) control code is transmitted when the buffer is nearly full while a DC1 control code (021₈) is transmitted when the buffer is empty. This method requires a full duplex connection with proper software handler at the processor end of the communications line. Communication may or may not be through a MODEM.

MODEM Control Signals

The serial interface support Bell model 103 and 212A compatible asynchronous MODEMs. The signals used by DASHER TP2 printers and their functions are given below:

SIGNAL	TYPE	FUNCTION
Transmit data	EIA or Current Loop	Carries data transmitted by the DASHER TP2 printer.
Receive data	EIA or Current Loop	Carries data received by the DASHER TP2 printer.
Data Set Ready	EIA	Input to printer. When high, indicates that the MODEM is powered-up, ready, and that a call has been received.
Data Terminal Ready	EIA	Output from printer. When high, indicates that the printer is powered up, ready, and aware that the MODEM is ready.
Request To Send	EIA	Output from printer. When low, indicates to the MODEM that the printer would like to transmit some data.
Clear To Send	EIA	Input to printer. When high, indicates that the MODEM is ready to transmit data it receives from the printer.

You should use a full duplex MODEM along with the software "busy" control codes mentioned above.

CABLING

You connect your printer to a computer or communications system using an I/O adapter cable. The various cables available are described below.

Parallel Interface I/O Cables

Five I/O adapter cables are available for the parallel model printers. Each cable is attached to the printer by a 36-pin Amphenol connector, 25-pin Cannon connector, a 50-pin edge connector, or a 100-pin edge connector.

PARALLEL INTERFACE CABLES

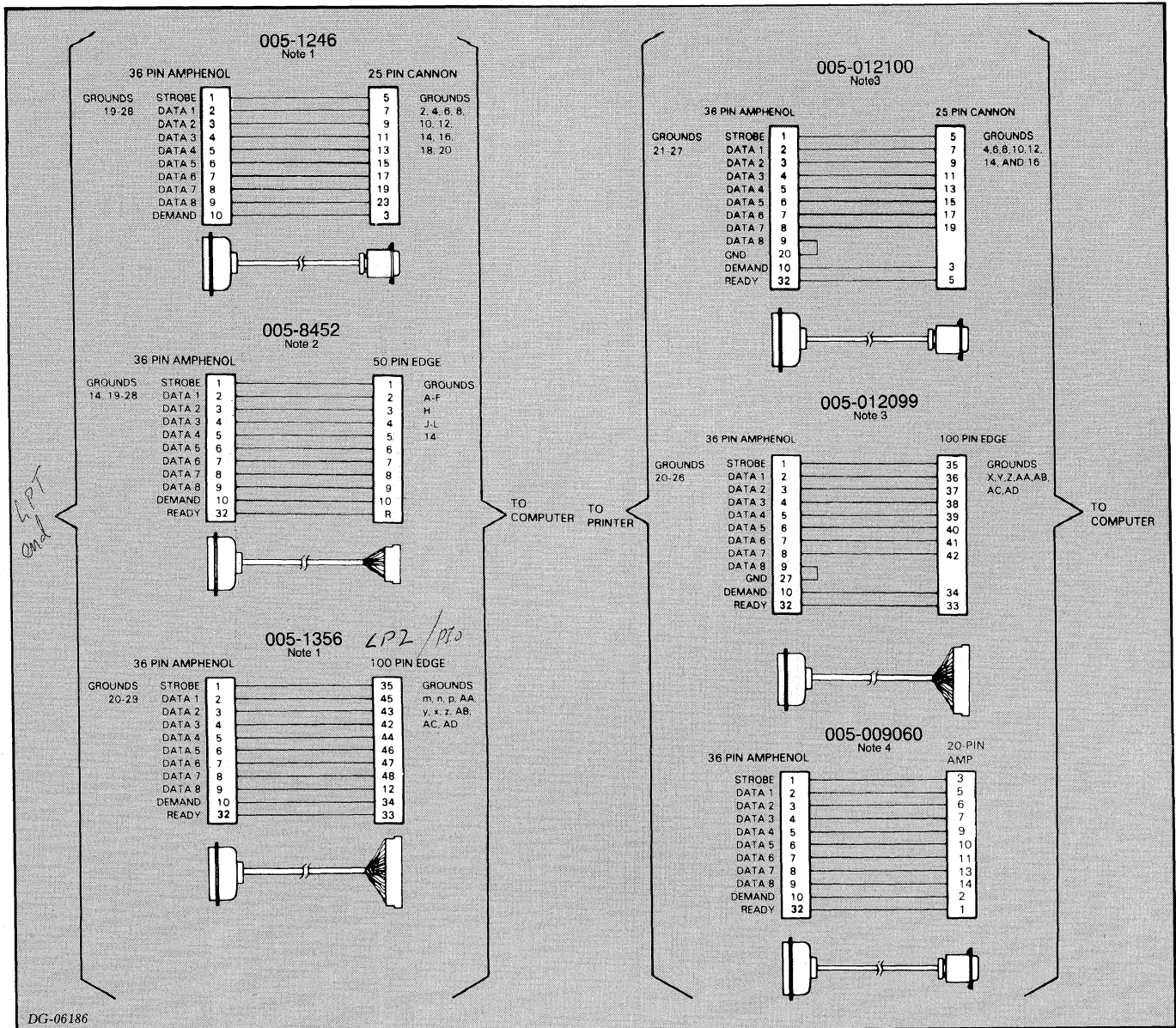

If you are making your own cable, it should not exceed 25 feet (7.4 meters) in length.

- Note 1: For use with DGC programmed I/O controllers.
- Note 2: For use with DGC microcomputer controllers.
- Note 3: For use with DGC data channel controllers.
- Note 4: For use with DGC CS Systems.

Printer Busy Signal

The function of a busy signal is to tell the transmitting device to stop sending data so that the printer's character buffer does not overflow (i.e., lose data). The DASHER TP2 printer's serial interface has two different methods for telling the transmitting device to stop sending information.

The first method uses a hardware busy signal provided in both EIA and current loop configurations. This method is designed for use with local connections to a processor (i.e., not through a MODEM). The signal is labeled RTS on the EIA connector (J29) and BUSY on current loop connection J28. The polarity of the hardware busy signal is switch selectable on the Control Logic PCB. The hardware busy signal is asserted when the buffer contains more than 2272 bytes. This signal notifies the controller to stop sending data because the buffer is nearly full. After the buffer drops below 512 bytes, the hardware busy signal is deasserted indicating that the controller can resume transmitting data.

The second method, called X/ON X/OFF, requires your printer to transmit one of two codes to the transmitting device, telling it to start or stop sending data. A DC2 (023₈) control code is transmitted when the buffer is nearly full while a DC1 control code (021₈) is transmitted when the buffer is empty. This method requires a full duplex connection with proper software handler at the processor end of the communications line. Communication may or may not be through a MODEM.

MODEM Control Signals

The serial interface support Bell model 103 and 212A compatible asynchronous MODEMS. The signals used by DASHER TP2 printers and their functions are given below:

SIGNAL	TYPE	FUNCTION
Transmit data	EIA or Current Loop	Carries data transmitted by the DASHER TP2 printer.
Receive data	EIA or Current Loop	Carries data received by the DASHER TP2 printer.
Data Set Ready	EIA	Input to printer. When high, indicates that the MODEM is powered-up, ready, and that a call has been received.
Data Terminal Ready	EIA	Output from printer. When high, indicates that the printer is powered up, ready, and aware that the MODEM is ready.
Request To Send	EIA	Output from printer. When low, indicates to the MODEM that the printer would like to transmit some data.
Clear To Send	EIA	Input to printer. When high, indicates that the MODEM is ready to transmit data it receives from the printer.

You should use a full duplex MODEM along with the software "busy" control codes mentioned above.

CABLING

You connect your printer to a computer or communications system using an I/O adapter cable. The various cables available are described below.

Parallel Interface I/O Cables

Five I/O adapter cables are available for the parallel model printers. Each cable is attached to the printer by a 36-pin Amphenol connector, 25-pin Cannon connector, a 50-pin edge connector, a 100-pin edge connector, or a 20-pin edge connector.

PARALLEL INTERFACE CABLES

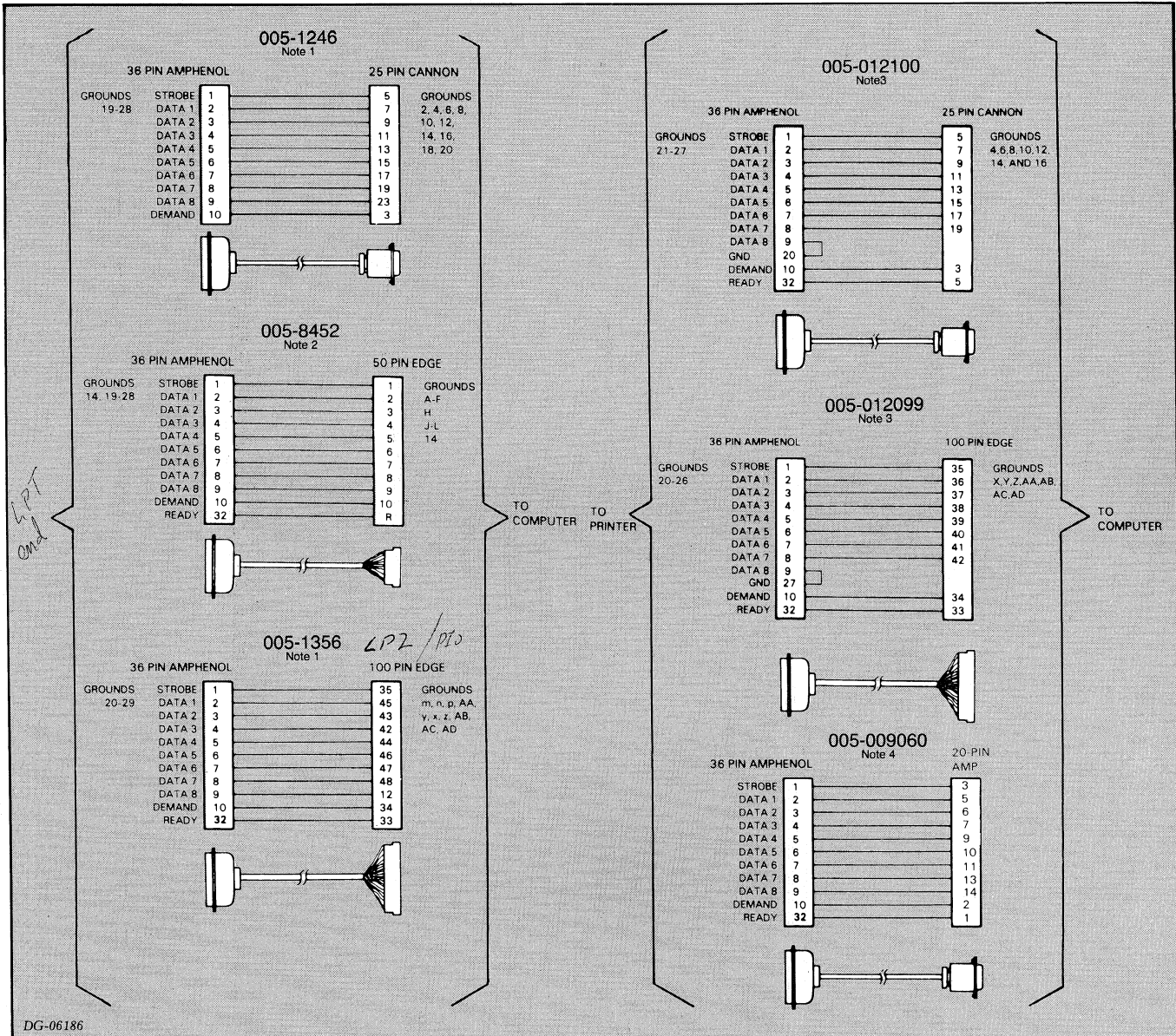

If you are making your own cable, it should not exceed 25 feet (7.4 meters) in length.

- Note 1: For use with DGC programmed I/O controllers.
- Note 2: For use with DGC microcomputer controllers.
- Note 3: For use with DGC data channel controllers.
- Note 4: For use with DGC CS Systems.

Serial Interface I/O Cables

Serial interface I/O cables come in a number of configurations. You can connect your printer to a system using either DASHER TP1/DASHER TP2 Series compatible cables, a MODEM cable, or a custom cable to which you may attach your own connector.

Cables using the EIA interface may be no longer than 50 feet (15.2 meters) while cables using the current loop interface may be up to 1500 feet (457 meters) long. The various cables which may be used with the serial interface are listed with their pin assignments in the accompanying diagram.

SERIAL INTERFACE CABLES

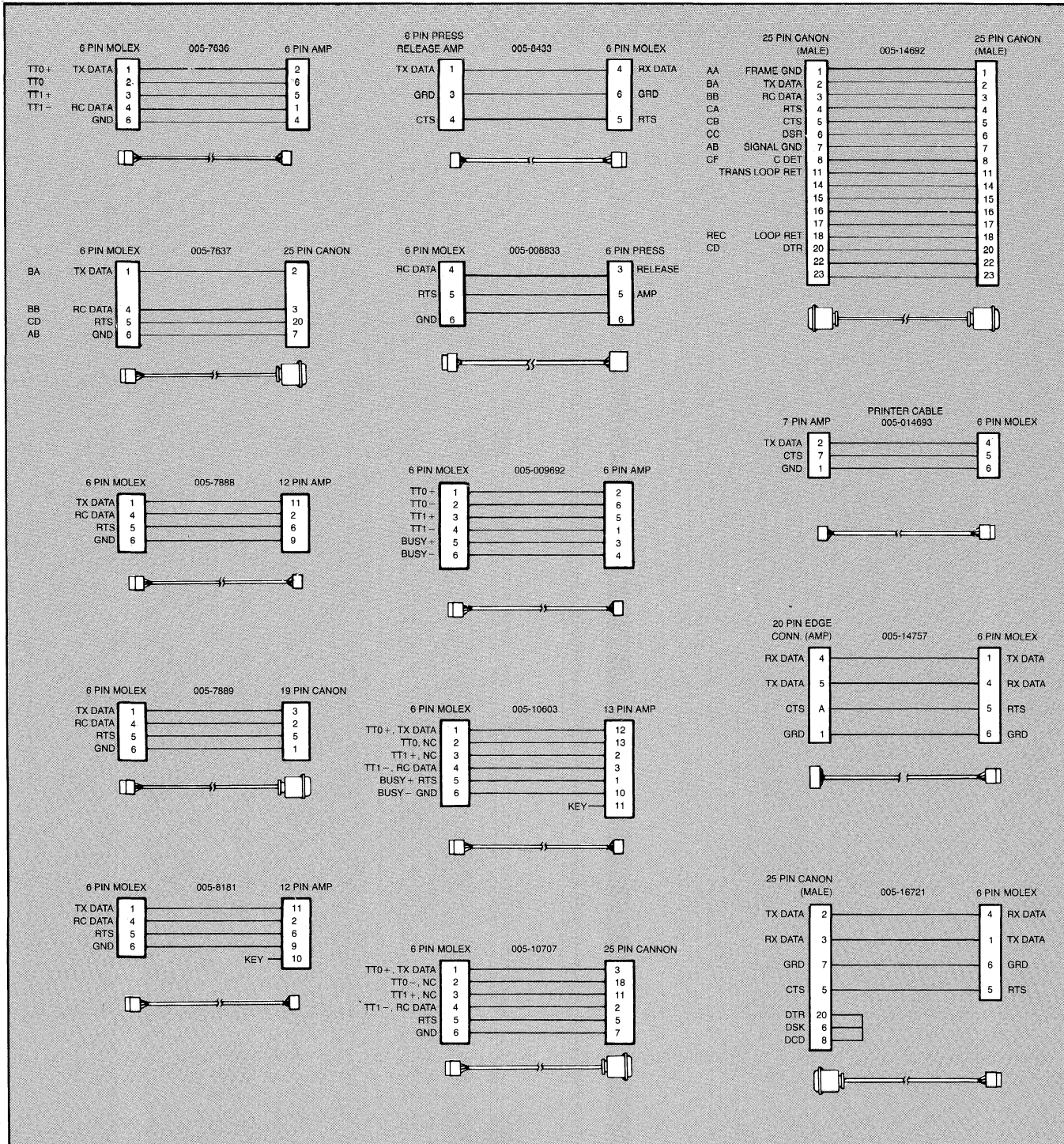

DASHER TP2 PRINTER EXTERNAL CABLES

CABLE CONNECTS		REMARKS	CABLE NUMBER	WIRELIST
TP2 CONNECTOR	COMPUTER/ CONTROLLER			
EIA/CL	ALM-16	BAUD RATES UP TO 4800 BAUD CAN BE RUN IF DC1 AND DC3 ARE USED.	005-007636	008-000971
EIA	MODEM	USED WITH SIMPLE MANUAL ANSWER MODEMS	005-007637	008-000973
EIA	NOVA 2, 3, 4, 820, 1210, 1220, ECLIPSE S100, S200, S230, C300, C330, S130, C150, AP130, S140, MICRONOVA	WHEN TP2 PRINTER IS A SECONDARY DEVICE (OR ANY DEVICE ON MICRO NOVA).	005-007888	008-002003
EIA	NOVA 800, 830, 840, 1200	—	005-007889	008-002002
EIA	ALM-8 CS SYSTEMS	TP2 IS A SECONDARY DEVICE ON CS SYSTEMS	005-008181	008-002033
EIA	ALL	D1, 2 R/O PRINTER	005-008433	008-002071
EIA	ALL	CS20, D3, R/O PRINTER	005-008833	008-002552
C.L.	CS SYSTEMS	ALLOWS USE OF CURRENT LOOP BUSY SIGNAL. CABLE LENGTH DEPENDS ON 005 CABLE #.	005-009692 005-009806 thru 005-009810	008-002125
EIA	NOVA 2, 3, 4, 820, 1210, 1220, ECLIPSE S100, S200, S230, C300, C330, S130, S140, C150, AP130	WHEN TP2 PRINTER IS THE PRIMARY CONSOLE	005-010603	008-002507
EIA/C.L.	MV8000, M600, S250, C350, NOVA 4, S140, CS10, C3.	—	005-010707	008-002542
EIA	MODEM	USED WITH AUTO-ANSWER, AUTO-DISCONNECT MODEMS	005-014692	018-000819
EIA	ALL	D100, 200 R/O PRINTER	005-014693	018-000820
EIA	CS10, C1	R/O PRINTER	005-014757	018-000886
EIA	MPT 80/83/87	R/O PRINTER	005-016721	018-000994

This page intentionally left blank.

CHAPTER IV INSTALLATION

CHOOSING A SITE

The illustration below gives you the necessary information for choosing a site for your DASHER printer.

SPECIFICATIONS

Item	Component	Number in Sub-system	Weight		Operating Humidity (Relative)		Maximum Operating Temperature			Power Dissipation (Watts)	BTUs/hr (3.41 x Watts)	Primary Power					Power Cable Length ft / m	Power Cable Connector	Power Drop Mating Power Receptacle	Wall Mating Power Receptacle	
			lbs	kg	min	max	Component °F / °C	Media °F / °C	Volt \pm			Hz	Phase	Cond	Amps						
		N/A	80	36.3	10%	90%	104°	40°	N/A	250	853	120	47-63	1	3	2.0	6	1.82	5-15P	5-15R	5-15R
		N/A	80	36.3	10%	90%	104	40	N/A	250	853	220 / 240	47-63	1	3	1.2 / 1.1	6	1.82	5-15P	5-15R	5-15R

* MINIMUM OPERATING TEMPERATURE: 50°F/10°C

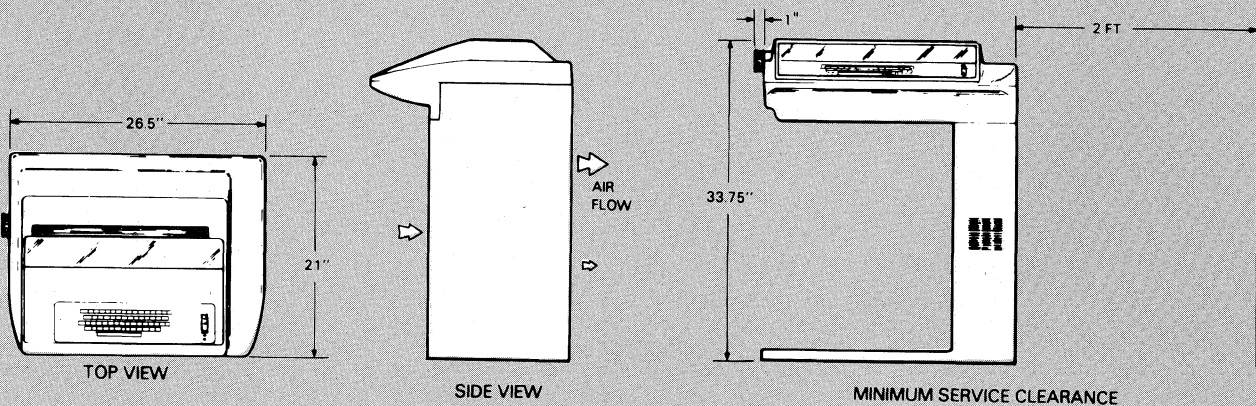

DG-02866

NOTE
REAR OF UNIT MUST BE AT LEAST 6"
FROM WALL OR OTHER OBSTRUCTION TO
PROVIDE COOLING AIR FLOW

This page intentionally left blank.

CHAPTER IV INSTALLATION

CHOOSING A SITE

The illustration below gives you the necessary information for choosing a site for your DASHER printer.

SPECIFICATIONS

Item	Component	Number in Sub-system	Weight		Operating Humidity (Relative)		Maximum Operating Temperature				Power Dissipation (Watts)	BTUs/hr (3.41 x Watts)	Primary Power					Power Cable Length ft / m	Power Cable Connector	Power Drop Mating Power Receptacle	Wall Mating Power Receptacle
			lbs	kg	min	max	Component °F	Media °C	°F	°C			°F	°C	Volt \pm	Hz	Phase				
		N/A	80	36.3	10%	90%	104°	40°	N/A		250	853	120	47-63	1	3	2.0	6 / 1.82	5-15P	5-15R	5-15R
		N/A	80	36.3	10%	90%	104°	40°	N/A		250	853	220 / 240	47-63	1	3	1.2 / 1.1	6 / 1.82	5-15P	5-15R	5-15R

* MINIMUM OPERATING TEMPERATURE: 50°F/10°C

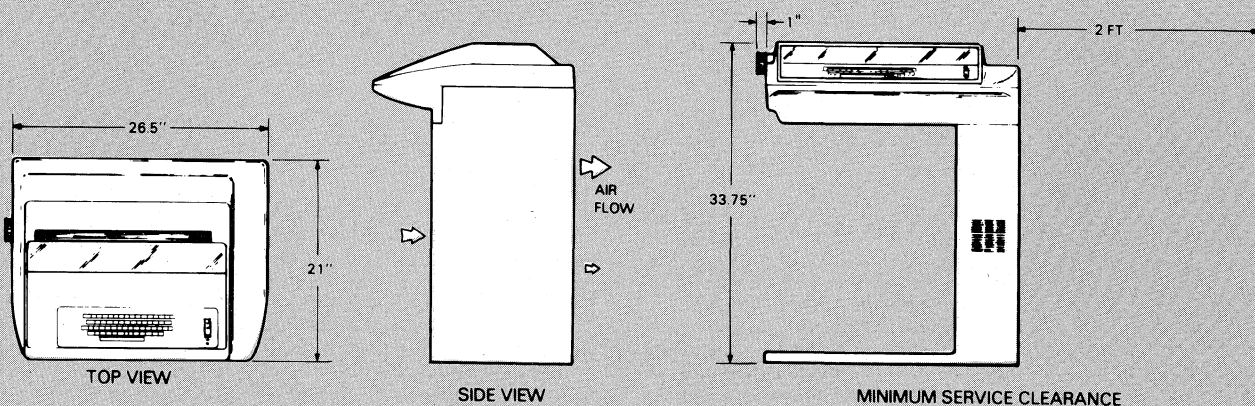

DG-02866

NOTE:
REAR OF UNIT MUST BE AT LEAST 6"
FROM WALL OR OTHER OBSTRUCTION TO
PROVIDE COOLING AIR FLOW

UNPACKING

After selecting a site, uncrate the printer as follows. Open top of box and remove cables and documentation from recessed area in top foam piece. Then remove

the top foam piece and stand printer in upright position (while still encased in box and lower foam piece). Remove the remainder of the foam and box. Then remove the four shipping bolts and washers as shown in the illustration below.

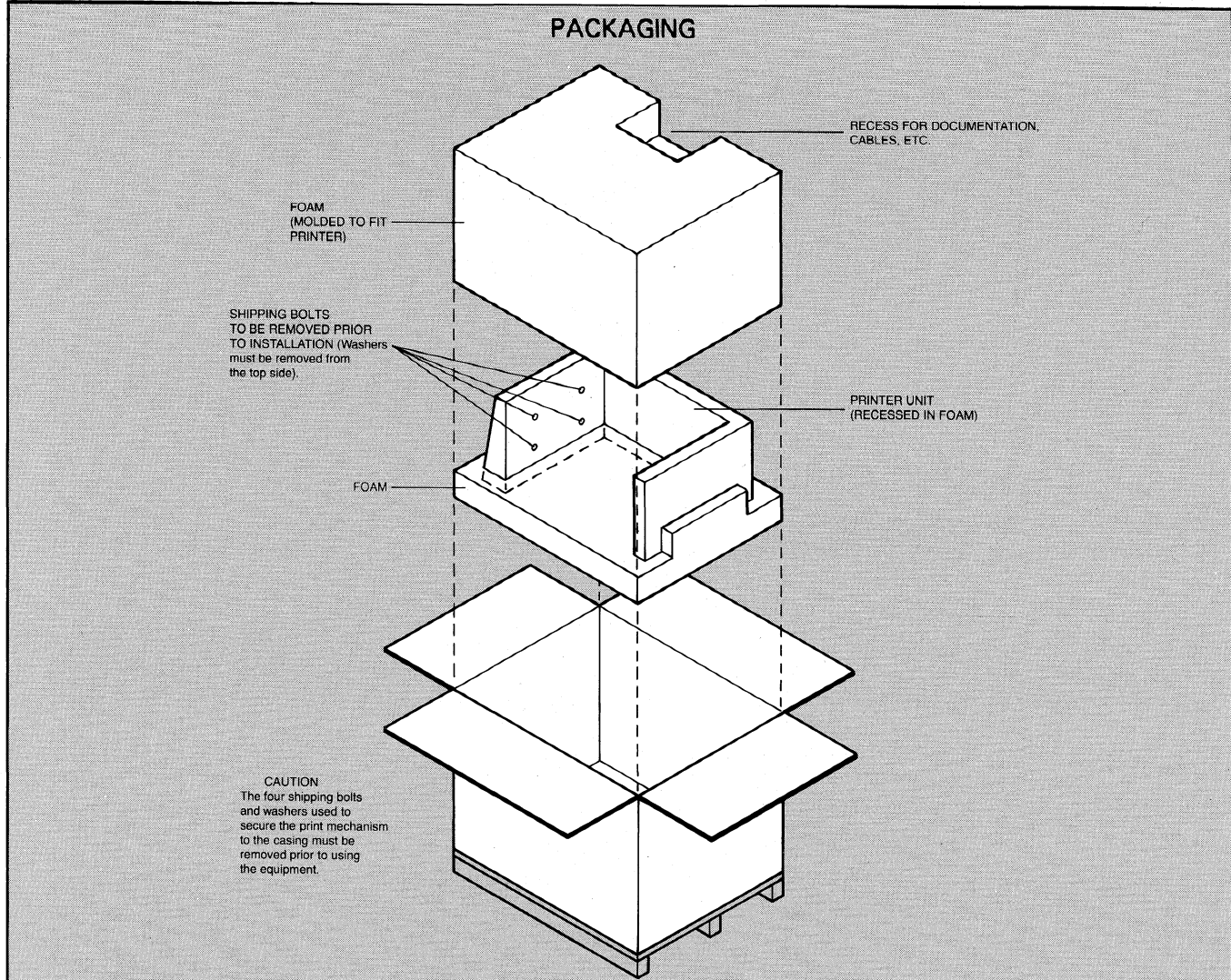

SHIPPING AND PACKAGE DATA					
Outside Dimensions			Weight (Gross)	Volume	Density
Length	Width	Depth			
in.	in.	in.	lbs.	cu ft.	lbs/cu ft.
cm	cm	cm	kg	cu m	kg/cu m
40.5	31.50	30.75	123	22.7	5.4
102.9	80.0	78.1	55	.6	87.8
SHIPPING SPECIFICATIONS			STORAGE SPECIFICATIONS		
Temperature Range	Relative Humidity	Maximum Altitude	Temperature Range	Relative Humidity	Maximum Period
°F	(Non-condensing)		°F	(Non-condensing)	
°C			°C		
-40 +160	0%/80%	50,000 ft. 15,200 m	40 +160	0%/80%	90 days
-49 +71			-40 +71		

DG-03224

CONFIGURATION PROCEDURES

The DASHER printers may be installed on a wide range of DGC systems and various features may be either enabled or disabled depending on the setting of various internal switches and the presence or absence of six internal jumper wires.

The DASHER printers are normally configured at the factory. However, all jumper wires and switch settings should be verified during initial installation.

The printers may also have to be reconfigured if moved to another system.

TP2 CONFIGURATION OPTIONS

The jumper wires and DIP switches used for TP2 printer configuration are located on the Main Control printed circuit board (PCB), DGC part no. 005-016362 as shown below.

The PCB is equipped with six jumper wires (W1 - W6) and three Dual Inline Package (DIP) switches (SW1 through SW3).

Each DIP switch contains eight bit positions labeled 1 through 8.

The individual assignments for the jumper wires and DIP switches on the TP2 Main Control PCB are summarized in the chart on the following page.

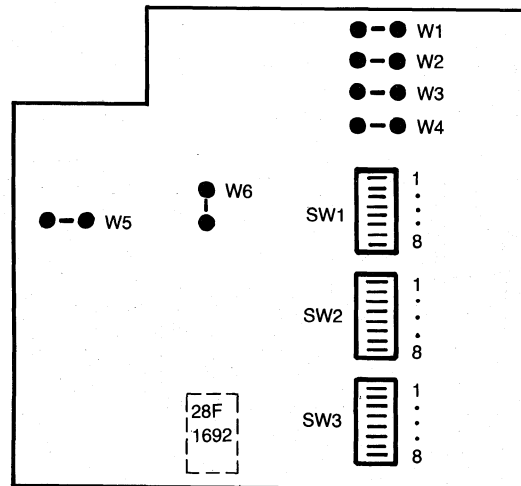

TP2 Control PCB (p/n 005-016362)

Note: IC 100-1692 installed on TP2 P/N 005-16710 through 005-16713.

LOCATION OF TP2 CONFIGURATION SWITCHES AND JUMPERS

TP2 CONFIGURATION SUMMARY

TP2 JUMPER WIRE ASSIGNMENTS		
JUMPER	IN/OUT	DESCRIPTION
W1	IN	Parallel I/F*
	OUT	Serial Interface
W2	IN	Power Failure Recovery Enabled
	OUT	Power Failure Recovery Disabled
W3	IN	SA Enabled (maintenance only)
	OUT	SA Disabled
W4	IN	APL Enabled
	OUT	APL Disabled
W5	IN	Clock Enabled
	OUT	Clock Disabled (Maintenance only)
W6	N/A	—

*Not a valid configuration for TP2 printers.

SWITCH NO.	SETTING	DESCRIPTION	
SW1	1-3 See Table	Standard Character Set Select	
	4-6 See Table	Alternate Character Set Select	
	7	On/Off	Alignment Adjust
	8	On	HW Busy Disabled
		Off	HW Busy Enabled
SW2	1	On	Parity Disabled
		Off	Parity Enabled
	2	On	Odd/Mark Parity
		Off	Even/Space Parity
3	On	Odd/Even Parity	
	Off	Mark/Space Parity	
4	On	Parity Fault Disabled	
	Off	Parity Fault Enabled	
5	On	8 Data Bits	
	Off	7 Data Bits	
6	On	1 Stop Bit	
	Off	2 Stop Bits	
7	On	HW Busy Low	
	Off	HW Busy High	
8	On	SW Busy Disabled	
	Off	SW Busy Enabled	
SW3	1	On	Current Loop Mode
		Off	EIA Mode
2	On	EIA Mode	
	Off	Current Loop Mode	
3	On	Busy to RTS Connect	
	Off	Busy to RTS Disconnect	
4	On	RTS Disabled High	
	Off	RTS Enabled	
5	On	DTR Disabled High	
	Off	DTR Enabled	
6	On	Current Loop Mode	
	Off	EIA Mode	
7	On	EIA Mode	
	Off	Current Loop Mode	
8		Not Used	

CHARACTER SET SELECT (SW1, BITS 1-6)						
STANDARD SET			ALTERNATE SET			SELECTED CHARACTER SET
SW1 BITS			SW1 BITS			
1	2	3	4	5	6	
ON	ON	ON	ON	ON	ON	American
ON	ON	OFF	ON	ON	OFF	British
ON	OFF	ON	ON	OFF	ON	German
ON	OFF	OFF	ON	OFF	OFF	Spanish
OFF	ON	ON	OFF	ON	ON	French
OFF	ON	OFF	OFF	ON	OFF	Danish
OFF	OFF	ON	OFF	OFF	ON	Swedish
OFF	OFF	OFF	OFF	OFF	OFF	Optional**

**American set if no optional character set has been installed.

TP2 CONFIGURATION GUIDELINES

The following jumper wire and switch bit settings represent a typical TP2 printer configuration. Additional

information is provided to permit the user to custom tailor the TP2's serial interface to match the requirements of the host system.

TP2 CONFIGURATION GUIDELINES

TP2 JUMPER WIRE SETTINGS		
JUMPER	IN/OUT	DESCRIPTION
W1	OUT	Serial Interface
W2	IN	Power Failure Recovery Enabled
W3	OUT	SA Disabled
W4	OUT	APL Disabled
W5	IN	Clock Enabled
W6	N/A	

TP2 SWITCH BIT SETTINGS			
SWITCH	BIT	SETTING	DESCRIPTION
SW1	1	ON	American character set select
	2	ON	
	3	ON	
	4	ON	
	5	ON	
	6	ON	
	7	ON/OFF	
SW2	4	ON	Adjust * Parity Fault Disabled
SW3	5	OFF	DTR Enabled

*Preset at Factory to OFF position

STOP BIT CONFIGURATIONS	
SW2 BIT6	NO. STOP BITS
ON	One Stop Bit
OFF	Two Stop Bits

CHARACTER LENGTH	
SW2 BIT5	LENGTH
OFF	Seven data bits
ON	Eight data bits

NOTE:

Normal Configuration: 7 data bits, selectable parity and selectable stop bits.

DLL Configuration: 8 data bits, no parity and one stop bit

INTERFACE OPTIONS			
HARDWARE BUSY CONFIGURATION			
SW1	8	OFF	HW Busy Enabled
SW2	7	ON	HW Busy Low
SW2	8	ON	SW Busy Disabled
SW3	3	ON	Busy to RTS
SW3	4	OFF	RTS Enabled
SOFTWARE BUSY CONFIGURATION			
SW1	8	ON	HW Busy Disabled
SW2	7	ON	HW Busy Low
SW2	8	OFF	SW Busy Enabled
SW3	3	OFF	Busy to RTS
SW3	4	ON	RTS Enabled
EIA CONFIGURATION			
SW3	1	OFF	EIA Modem
SW3	2	ON	EIA Modem
SW3	6	OFF	EIA Modem
SW3	7	ON	EIA Modem
20 MIL CURRENT LOOP			
SW3	1	ON	Curr. Loop Mod.
SW3	2	OFF	Curr. Loop Mod.
SW3	6	ON	Curr. Loop Mod.
SW3	7	OFF	Curr. Loop Mod.

PARITY CONFIGURATIONS			
SW2 BIT POSITIONS			SELECTED PARITY
1	2	3	
ON	OFF	OFF	No Parity
OFF	ON	OFF	Mark Parity
OFF	OFF	OFF	Space Parity
OFF	OFF	ON	Even Parity
OFF	ON	ON	Odd Parity

LP2 JUMPER/SWITCH OPTION DESCRIPTIONS

The jumper wire and DIP switch bit assignments for

the LP2 Main Control PCB are summarized in the following chart:

LP2 CONFIGURATION SUMMARY

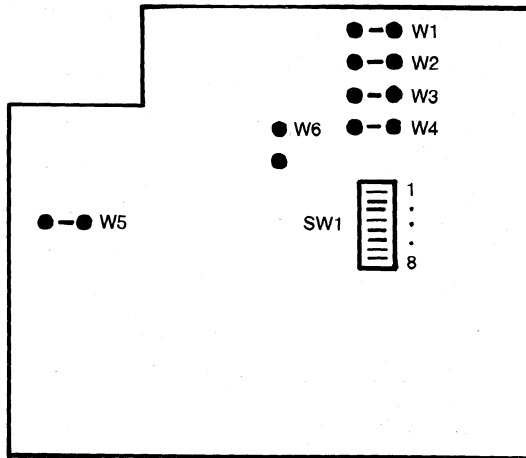

LP2 Control PCB (p/n 005-016360)

LP2 SWITCH BIT SETTINGS			
SWITCH	BIT	SETTING	DESCRIPTION
SW1	1	See Table	Standard character set select
	2	Below	
	3	Below	
	4	See Table	Alternate character set select
	5	Below	
	6	Below	
	7	ON/OFF	Alignment Adjust *
	8	N/A	—

*Preset at factory to OFF position

LP2 JUMPER WIRE ASSIGNMENTS		
JUMPER	IN/OUT	DESCRIPTION
W1	IN	Parallel I/F Serial Interface *
	OUT	
W2	IN	Power Failure Recovery Enabled
	OUT	
W3	IN	SA Enabled (maintenance only) SA Disabled
	OUT	
W4	IN	APL Enabled APL Disabled
	OUT	
W5	IN	Clock Enabled Clock Disabled (Maintenance only)
	OUT	
W6	IN	8-bit Interface 7-bit Interface
	OUT	

*Not a valid configuration for LP2 printers

CHARACTER SET SELECT (SW1, BITS 1-6)							SELECTED CHARACTER SET
STANDARD SET			ALTERNATE SET				
SW1 BITS			SW1 BITS				
1	2	3	4	5	6		
ON	ON	ON	ON	ON	ON	American	
ON	ON	OFF	ON	ON	OFF	British	
ON	OFF	ON	ON	OFF	ON	German	
ON	OFF	OFF	ON	OFF	OFF	Spanish	
OFF	ON	ON	OFF	ON	ON	French	
OFF	ON	OFF	OFF	ON	OFF	Danish	
OFF	OFF	ON	OFF	OFF	ON	Swedish	
OFF	OFF	OFF	OFF	OFF	OFF	Optional**	

**American set if no optional character set has been installed.

LP2 CONFIGURATION GUIDELINES

The following jumper wire and DIP switch settings reflect a typical LP2 printer configuration.

LP2 JUMPER WIRE CONFIGURATION		
JUMPER	IN/OUT	DESCRIPTION
W1	IN	Parallel I/F
W2	IN	Power Failure Recovery Enabled
W3	OUT	SA Disabled
W4	OUT	APL Disabled
W5	IN	Clock Enabled
W6	IN	8-bit Interface

LP2 SWITCH BIT SETTINGS			
SWITCH	BIT	SETTINGS	DESCRIPTION
SW1	1	ON	American character set select
	2	ON	
	3	ON	
	4	ON	American character set select
	5	ON	
	6	ON	Alignment Adjust *
	7	ON/OFF	
	8	ON/OFF	HDW Busy Disable/Enable

*Preset at factory to OFF position

OPERATION CHECK-OUT

We recommend you check out your printer before beginning to use it. This check-out consists of two parts: (1) an offline check-out after you unpack and tailor your printer, and (2) an online check-out after you connect it to your system. Before conducting these check-outs, familiarize yourself with the Operator's Manual (014-000678).

Offline Check-out

After you unpack and tailor your printer:

- Plug the 12-pin end of the power cord into the unit's power socket just above the circuit breakers on the back of the pedestal column;
- Plug the 3-pin end into the ac line supply outlet;
- Load paper and a ribbon cartridge as described in the Operator's Manual;
- Activate automatic form feed by following the procedure outlined in the Operator's Manual.

You are now ready to conduct the Offline Check-out.

Offline Check-Out Procedures

PROCEDURE	EXPECTED RESULT
Turn the power ON, switch the unit OFF LINE, and switch VIEW off.	The fan spins and the printhead returns to column one.
* Type a line of text without a NEWLINE.	The text is printed as you type.
* Press the CARRIAGE RETURN key.	The printhead moves to the left-hand margin of the same line.
* Press the NEWLINE key.	The paper advances one line.
* Type more text followed by a NEWLINE.	The text is printed as you type and the printhead moves to the left-hand column of the next line.
Press the FEED switch to the single line feed position several times (on KSR models press the LF FF key several times).	The paper advances one line each time you press the switch.
Hold the FEED switch in the continuous line feed position (on KSR models hold down the LF/FF key).	The paper is advanced to the top of the next form.

* Applies to testing KSR terminals only.

CONTINUED

Offline Check-Out CONTINUED

PROCEDURE	EXPECTED RESULT
<p>*Press an alphanumeric key and the RPT key simultaneously.</p> <p>Check the form feed feature as follows:</p> <p>Advance the paper to the top of the next form. Set the line count thumbwheels to the line count corresponding to the length of the form you are using. Press and release the TOF INIT pushbutton and press the FEED switch to the continuous line feed position (hold the LF/FF switch down on KSR models).</p>	<p>The alphanumeric character is printed repeatedly until you release one of the keys.</p> <p>The paper advances to the top of the next form.</p>

* Applies to testing KSR terminals only.

NOTE: *View mode operates in ONLINE mode only.*

Online Check-out

Before you can conduct the online checkout, you need to connect your printer to a computer or communications system as follows:

- Plug the printer end of the I/O adapter cable or custom cable (see Cabling, Chapter III, for information about cables) into the appropriate connector on the back side of the pedestal column as shown below.
- Connect the other end to the system.

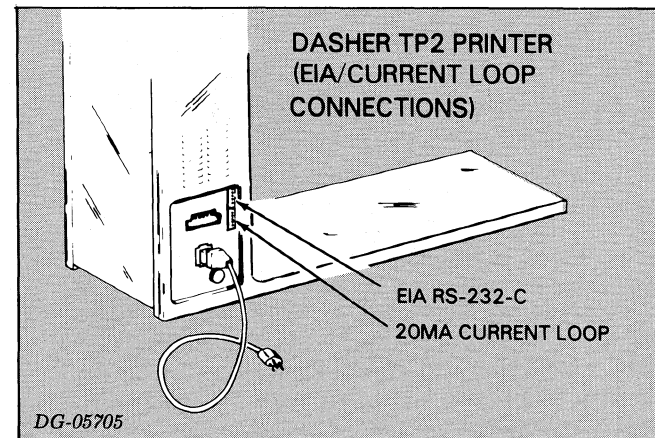
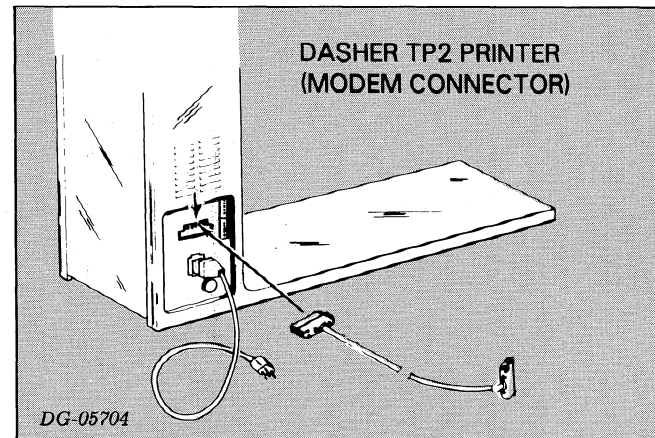
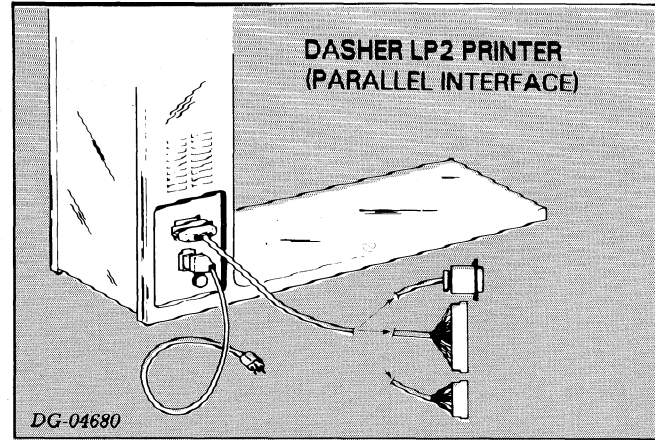

If you have an RO model printer, load a program into your system that transmits ASCII characters to the printer. If you have a KSR terminal, load a program into your system that transmits codes received from your keyboard back to the printer. Now you are ready to conduct the online check-out.

Online Check-Out Procedures

PROCEDURE	EXPECTED RESULT
Switch the power ON and switch your printer ON LINE.	The fan spins and the printhead returns to the left-hand margin. The ON LINE and RDY indicators light.
With the printer online, repeat the steps of the offline check-out.	The results are identical to the steps in the offline check-out.
Check the form feed as follows:	
Switch the printer OFF LINE. Activate the the automatic perforation skip-over feature, set the line count thumbwheels to the number of lines corresponding to length of the form you are using, adjust the paper so that the printhead is about 1/2 inch below the top of the form, and press and release the TOF INIT pushbutton. Switch the printer ON LINE.	No visible result.
Type several lines of text and press the CTRL and the L keys simultaneously. (For an RO terminal, transmit an appropriate number of ASCII printing characters followed by a Form Feed character.)	The text is printed as you type and the paper advances to 1/2 inch below the top of the next form.
Type in (or transmit) the same number of lines as set by the line count thumbwheels.	The text is printed until you reach the sixth line from the bottom. The paper advances to 1/2 inch below the top of the next form, and the rest of the text is printed.
* Type in (or transmit): <ul style="list-style-type: none"> - a few NEWLINES (012) - ESC - 5 (033 065) (sets vertical tab) - a CTRL - L (014), (a form feed) - CTRL - K (013) (a vertical tab) 	Paper advances a few lines, proceeds to the top of the next form, and advances to the line in which the vertical tab is set.

PROCEDURE	EXPECTED RESULT
Type in (or transmit) a word or two followed by: <ul style="list-style-type: none"> - ESC - 1 (033 061) (sets horizontal tab) - NEWLINE (015) - CTRL - 1 (011) 	The text is printed as you type (or transmit), a horizontal tab is set at the end of the text, the printhead returns to the beginning of the next line and tabs out to the position where the tab was set (after the last character typed on the line above).
Type in (or transmit): <ul style="list-style-type: none"> - some text - ESC < (033 074) - more text 	<ul style="list-style-type: none"> - The text is printed. - Nothing happens. - The text is printed in elongated width characters. - Nothing happens. - The text is printed in normal width characters.
Type in (or transmit): <ul style="list-style-type: none"> - some text - ESC a (033 141) - some text - ESC b (033 142) - some text 	<ul style="list-style-type: none"> - The text is printed. - Nothing happens. - The text is printed is underscored. - Nothing happens. - The text is printed without an underscore.
Type in (or transmit): ESC c NULL (033 143 000)	The printer reinitializes itself according to the settings of the Secondary Control Panel (see Operator's Manual). The printhead returns to the left-hand margin.
**Type in (or transmit): <ul style="list-style-type: none"> - NEWLINE (012) - ESC > (033 076) - some text 	<ul style="list-style-type: none"> - Printhead returns to left-hand margin. - Carriage seeks home. - Text is printed in compressed width characters.
<ul style="list-style-type: none"> - NEWLINE (012) - ESC ? (033 077) - more text 	<ul style="list-style-type: none"> - Printhead returns to left-hand margin. - Carriage seeks home. - Text is printed in normal width characters.

*Left if current position ≤ 9 positions from right end.

This completes the check-out of your printer. If you did not get the expected result, check the input power, the cabling connections, the jumpers on the main PC board, and the coding of the program transmitting or echoing characters to your printer. (It may also

be helpful at this time to check the Troubleshooting Guide in the Operator's Manual.) Repeat the appropriate checkout procedures. If your printer still does not function correctly, contact the nearest field service representative for assistance.

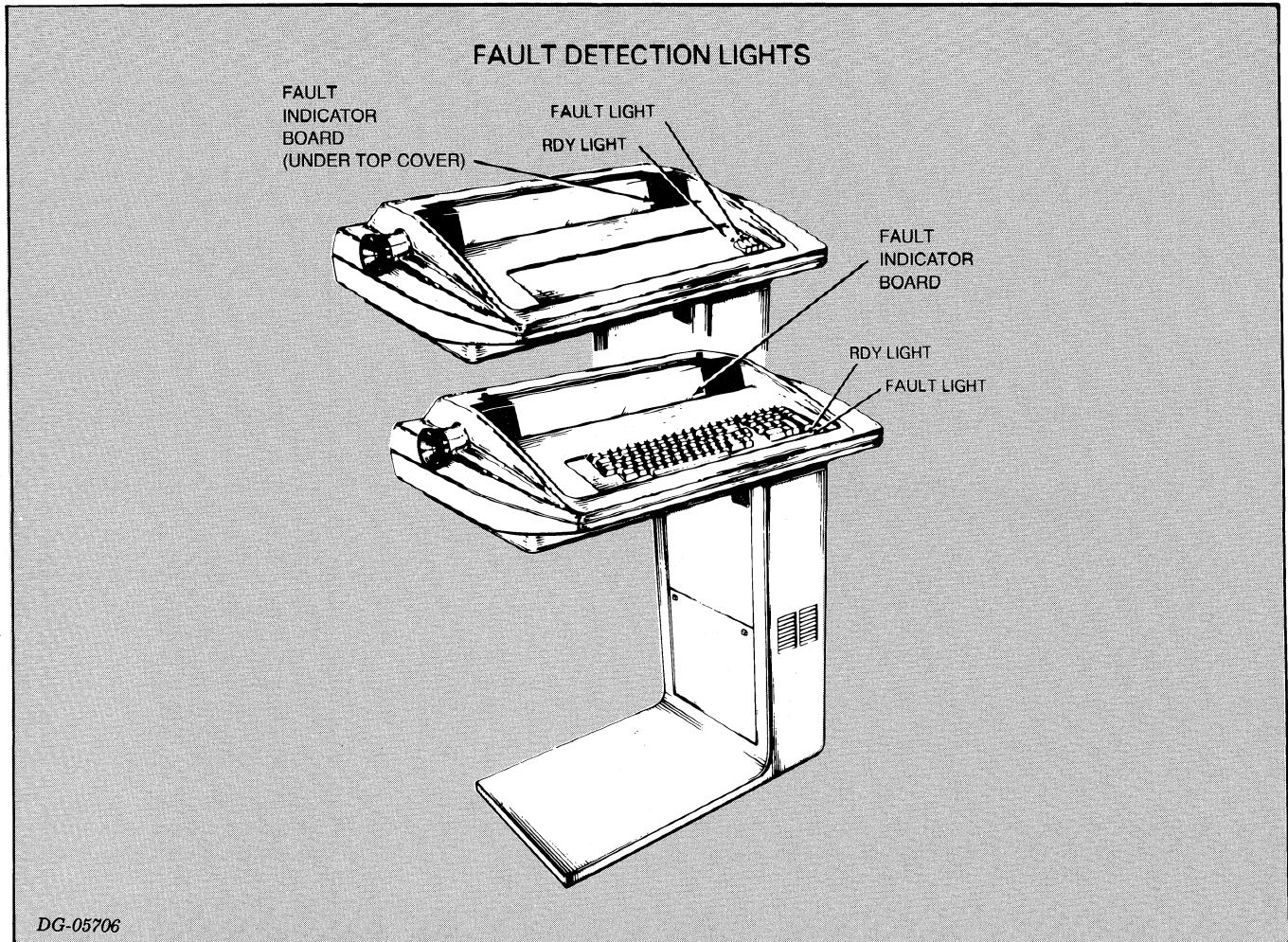

FAULT DETECTORS

Power Line Circuit Breaker

A circuit breaker protects your unit from overcurrent situations. There is usually a good reason for a circuit breaker tripping; therefore, we recommend that you call a qualified service representative in the event of a problem.

A portion of the circuit breaker pops out in the event of a short. You reset a breaker (with the power switch Off) by pressing in the cylinder. If this breaker will not reset, wait 5 minutes and try again. **DO NOT FORCE** breaker reset or damage may result.

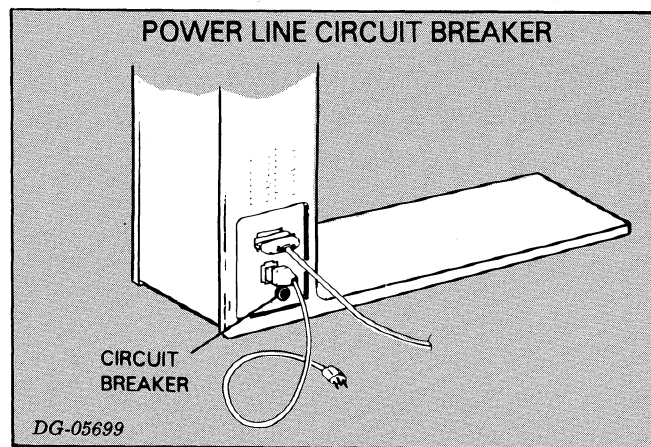

RDY (Ready) Light

The RDY light on the primary control panel indicates that the printer is online and no fault conditions exist.

Fault Light

The FAULT LED on the primary control panel lights when a problem exists that requires operator intervention. The nature of the problem can then be determined by evaluating the fault code displayed on the Fault Indicator Board.

Fault Indicator Board

The seven-segment LED on the Fault Indicator Board displays a numerical fault code anytime an operational or equipment fault is encountered. Each time the display is updated, a bell is sounded to alert the operator.

Self Test Failure Faults (Codes 1, 2 and 3)

When the printer is initially powered up or master reset, a self test is performed on the printer's memory circuits (ROM and RAM) and on the serial interface logic (TP printers only). A failure on any of these tests will result in one of the following error codes:

ERROR CODE	FAULT DESCRIPTION
0	Processor not executing code
1	ROM Self Test failure
2	RAM Self Test failure
3	Serial I/F failure

After a self test failure occurs, the test is executed continuously and the fault indication remains until the printer successfully passes the test.

An error message display 0 thru 3 is an indication of a hardware problem and the user should contact the nearest Data General Field Service Office for assistance.

Operational Faults (Codes 4-C)

From time to time, printer conditions occur that require operator intervention before normal operations can be resumed. These conditions and their associated fault codes are as follows:

FAULT CODE	CONDITION
4	Parity error
5	Carriage motor stall
6	(Future expansion)
7	Out of forms
9	Buffer overflow
C	Power failure recovery

OPERATIONAL FAULTS (Continued)

Parity Error (4)

The parity error fault indication is switch selectable on the control logic PCB (see Installation Chapter).

Carriage Motor Stall (5)

This fault can be caused by a ribbon cartridge jam, buildup of foreign matter on the leadscrew/guide shafts, or other similar problems.

Out of Forms (7)

This fault indicates the printer is out of paper or that the paper is no longer feeding into the printer for some reason.

System O.K. (8)

This indication is temporarily displayed after completion of self test.

Buffer Overflow (9)

This fault indicates that the correct busy signal is not configured on the control logic PCB (see Installation Chapter) or that the host system did not respond to the selected busy signal.

Power Failure Recovery (c)

This fault indication informs the operator that a power failure has occurred and prevents going directly from a power failure to an ONLINE condition (if desired).

To enable this fault circuit, the Power Fail Recovery feature must be disabled on the control logic PCB (if enabled, the Power Failure Recovery fault will never occur).

Operational Fault Recovery

To recover from an operational fault, the fault condition must first be cleared and then the FAULT reset switch must be pressed on the Fault Indicator Board.

The forms override function is performed by holding the FAULT RESET switch down to print additional lines after the OUT OF FORMS fault occurs.

CHAPTER V

ARCHITECTURE

INTRODUCTION

Your printer is controlled by an 8-bit microprocessor. The microprocessor directs communication between a number of a DASHER LP2 and TP2 printer's basic subsystems. These subsystems include:

- Memory
- Printhead and carriage assembly
- Paper feed assembly
- Control panels
- Keyboard and numeric pad
- Parallel interface or serial interface

Information is transferred between these subsystems and the microprocessor along a bidirectional bus.

THE MICROPROCESSOR

The microprocessor-based design eliminates costly hard-wired logic and provides the printer with greater power and flexibility. Its programmable nature makes possible many of the printer's special features such as horizontal tabbing, vertical tabbing, and elongated characters.

The microprocessor's main function is to control the printer's various subsystems. The manner in which these subsystems are controlled is determined by the microprocessor's program.

MEMORY

The memory subsystem stores the microprocessor's program and variables, characters received from the computer, and special codes used by the microprocessor to fire the print wires.

Your printer has two types of memory: read-only memory and random-access memory. Read-only memory is used exclusively for storing the operating program. This type of memory cannot be altered by the microprocessor. Its contents are not lost when you power-down your printer. Random-access memory is used to store program data and incoming characters.

The contents of the random access memory include characters received but not yet printed and downloaded character set dot patterns. These are lost when the printer is powered down and when a Master Reset is generated.

PRINthead AND CARRIAGE ASSEMBLY

The printhead and carriage assembly is the mechanism which prints characters. The following diagram illustrates the various components of this subsystem.

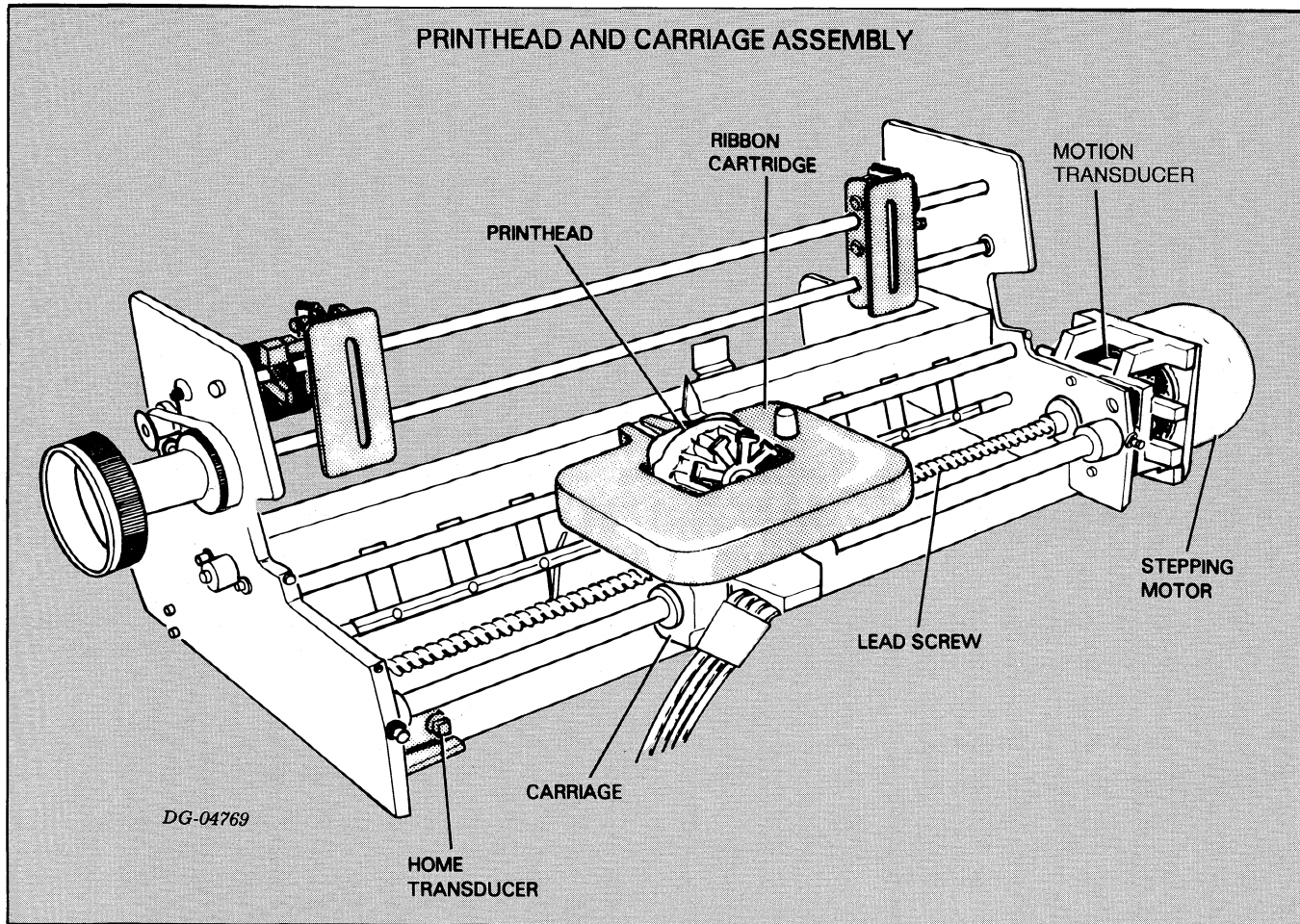

The Printhead

The printhead forms a character in seven segments as it moves across the paper. Each segment is formed by firing a subset of the 9 printhead wires. These wires force the ribbon against the paper forming a 7 by 9 dot matrix character. The microprocessor fires these print wires by obtaining a 9-bit code from the character generator and transmitting that code to the printhead. The illustration below shows how a character is formed during a left to right print sequence.

Since printing is bidirectional, a character may also be formed by starting with its right column. In this case, the microprocessor issues the firing codes in reverse order.

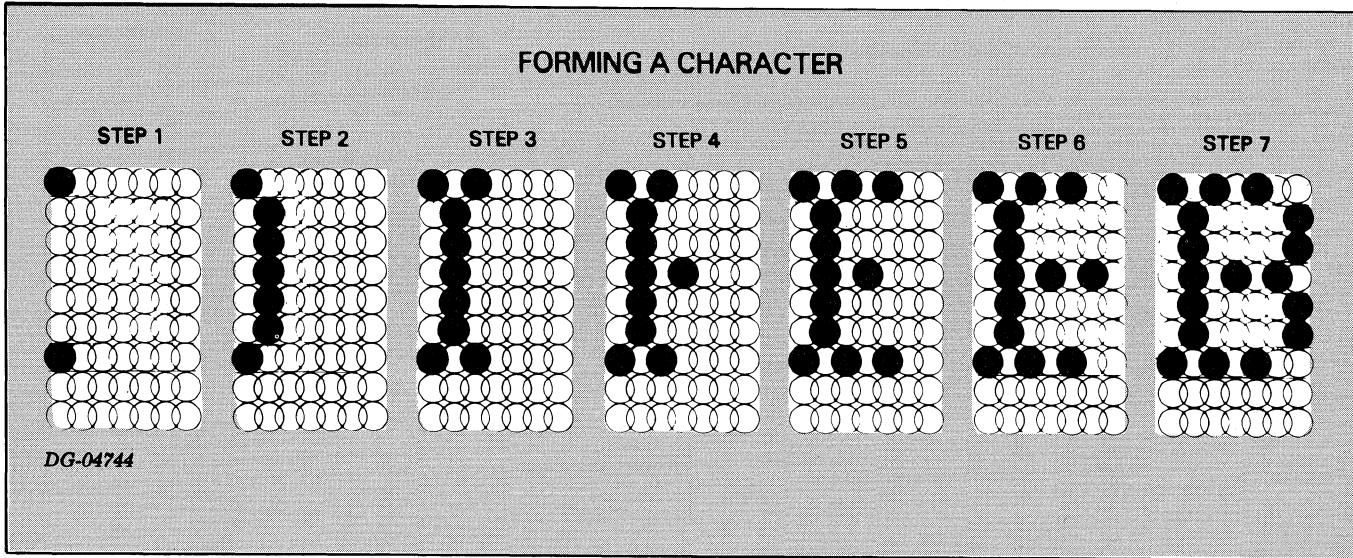

The Carriage

The microprocessor controls the horizontal motion of the printhead by issuing commands to the drive circuitry of the carriage mechanism. This mechanism consists of a stepping motor and lead screw assembly (to which the printhead carriage is attached). When the microprocessor steps this motor (tells it to rotate a fixed amount), the lead screw turns, moving the printhead a fixed distance. Since the stepping motor may be stepped clockwise or counter-clockwise, the printhead may be moved either right or left.

Position Transducers

One of the transducers is used to inform the microprocessor when the printhead has reached the left-hand margin (home position). This transducer initializes the printhead's horizontal alignment.

Another transducer rotating with the shaft is used to indicate when the carriage is moving and the motor is not stalled.

PAPER FEED ASSEMBLY

The paper feed assembly controls the vertical movement of paper past the printhead. Like the carriage mechanism, the paper feed assembly uses a stepping motor. This motor turns the tractors which move the paper by the printhead. The microprocessor directly controls how much paper is fed through the printer by stepping this motor a selected number of times. In fact, the difference between selecting 6

lines/inch or 8 lines/inch spacing is reflected in the number of steps the microprocessor issues to the stepping motor for a line feed.

Sensing Paper Movement

A switch informs the microprocessor when paper runs out. If this occurs, the microprocessor generates a fault.

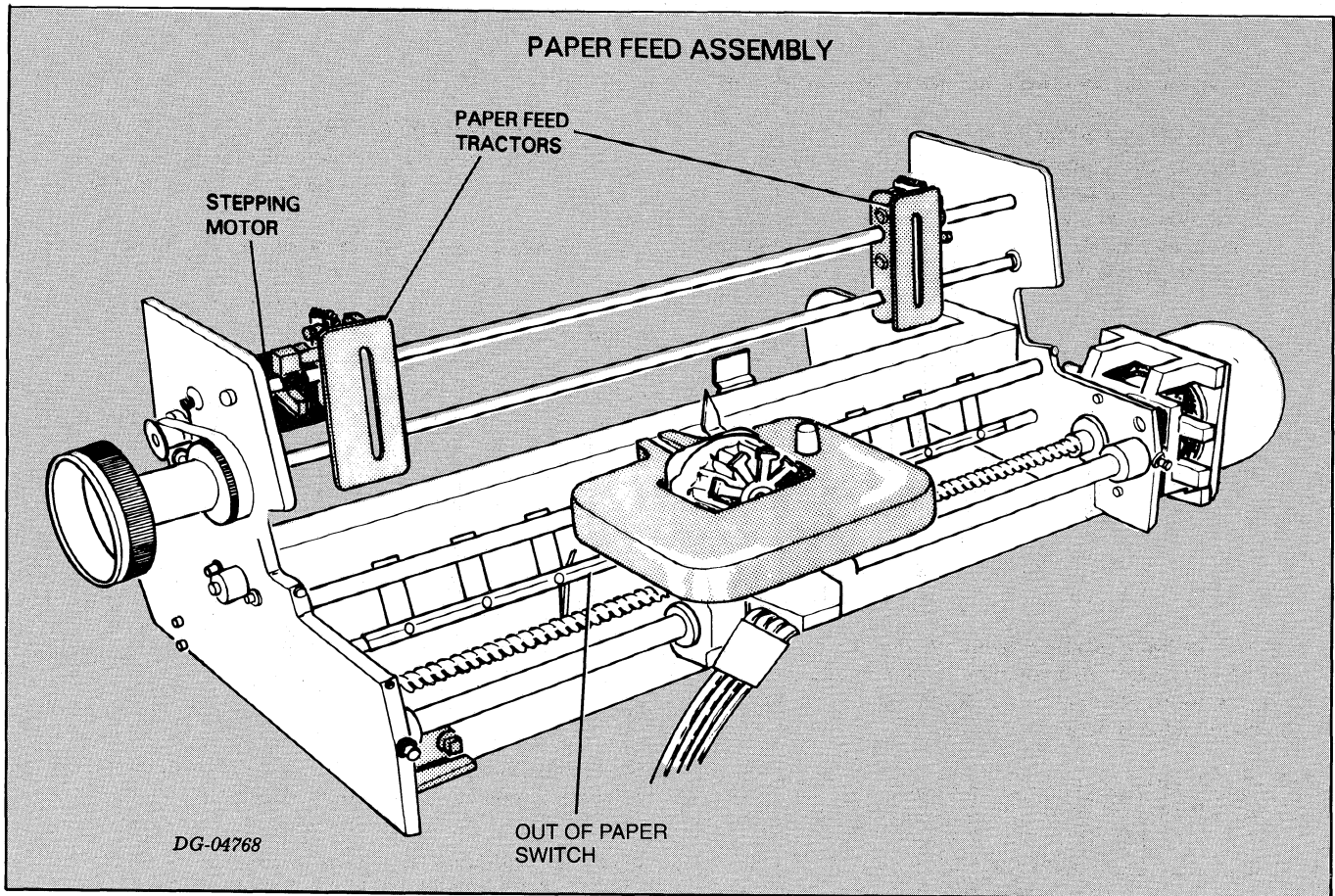

PRINTER CONTROL PANELS

The printer contains two control panels: a primary control panel located on the top cover and a secondary control panel accessed by raising the top cover.

Primary Control Panel

The primary control panel contains three switches including:

- ON/OFF LINE
- LINE FEED/FORM FEED
- VIEW MODE

These switches are checked each time the carriage stops. While the carriage remains stopped, the switch states are monitored approximately every 6 milliseconds.

The primary control panel also contains the following LED indicators:

- **READY** — Unit online and no fault conditions exist.
- **ONLINE** — Lights when unit is ONLINE, goes out when printer is OFFLINE.
- **FAULT** — Lights when a fault is detected. If a fault is detected, the unit indicates Busy and Not Ready status, and ceases printing until the fault is corrected and then cleared via the FAULT RESET switch.
- **VIEW (TP models only)** — Indicates when the view mode is active (active only in ONLINE mode). In the view mode, the carriage moves 9 character positions to permit viewing the most recently typed characters.

SECONDARY CONTROL PANEL

The secondary control panel contains the control switches that are least often accessed by the operator. These switches include:

- Compressed/Normal Mode switch
- 6/8 line per inch switch
- 0-99 lines per form (thumbwheel switch)
- Top of Form Initialize switch
- Perforation Skipover Disable
- Master Reset switch
- Self Test/ESC Disable switch
- Baud Rate switch
- Primary/Alternate Character Set Select switch

KEYBOARD AND NUMERIC PAD

Some TP model printers are equipped with an ASCII keyboard. While this unit is online, codes of depressed keys are transmitted to the host system over the serial interface. Since only full duplex protocol is supported, the character is not printed until echoed back by the host.

When the keyboard equipped unit is offline, it functions as a typewriter with a limited set of control codes including:

OCTAL CODE	FUNCTION
007	Bell
010	Backspace
012	Newline
015	Carriage Return

THE PARALLEL INTERFACE

A parallel interface transfers data from a computer to the microprocessor. Seven or eight data lines transfer data from the computer to the interface. A *demand* line informs the computer when your interface is able to accept data. A second status line, *Ready*, informs the computer whether your printer is powered up and online with no fault conditions.

The microprocessor continually checks the interface to see if any data is present. If it finds that a byte has arrived, the microprocessor retrieves this byte from the interface and stores it in memory for processing. The parallel interface can accept data at a rate up to 5,000 characters/second until the allotted storage area in memory is filled. At this point, the microprocessor processes most of the stored characters before it accepts any additional characters.

SERIAL INTERFACE

The serial interface transfers data in either direction between the printer and a communications system. This interface, available on both RO Printer and KSR terminals in a number of jumper selectable serial formats. In additions, you may select one of eight different information transfer rates (110, 150, 300, 600, 1200, 1800, 2400, and 4800 baud).

Reception

The serial interface assembles data in an 8-bit buffer as it is received, notifying the microprocessor when the complete byte is present. The microprocessor then retrieves the byte and stores it in memory for processing.

Transmission

When the microprocessor wishes to transmit a character, it first checks the serial interface to see if it is busy transmitting a character. When the interface is idle, the microprocessor transfers the byte (character) to the interface.

POWER SUPPLY

The printer's power supply provides six different dc supply voltages from either 120 volt or 220/240 volt ac power sources (47-63 Hz). The design uses pulse-width modulation to regulate the output voltages. In addition, overvoltage and overcurrent detection protect the supply against fluctuations in line voltage.

APPENDIX A

ASCII - 128 CHARACTER CODES

NAME OR MNEMONIC	ACTION TAKEN BY PRINTER	ASCII CODE (OCTAL)	DECIMAL EQUIVALENT	KEYS ** PRESSED TO GENERATE CODE
NUL	None	000	000	CTRL O
SOH	None	001	001	CTRL A
STX	None	002	002	CTRL B
ETX	Reserved	003	003	CTRL C
EOT	Reserved	004	004	CTRL D
ENQ	None	005	005	CTRL E
ACK	Reserved	006	006	CTRL F
BEL	Sounds audible tone	007	007	CTRL G
BS	Back Space (online only)	010	008	CTRL H ● BS ● SHIFT BS ● CTRL BS
HT	Horizontal Tab	011	009	CTRL I ● TAB ● SHIFT TAB ● CTRL TAB
NL	Newline (Line Feed)	012	010	CTRL J ● LF ● SHIFT LF ● CTRL LF
VT	Vertical Tab *	013	011	CTRL K
FF	Form Feed *	014	012	CTRL L
CR	Carriage Return	015	013	CTRL M ● CR ● SHIFT CR ● CTRL CR ● (NP)
SO	Selects Alternate Character Set	016	014	CTRL N
SI	Selects Standard Character Set	017	015	CTRL O
DLE	None	020	016	CTRL P
DC1	None	021	017	CTRL Q
DC2	None	022	018	CTRL R
DC3	None	023	019	CTRL S
DC4	None	024	020	CTRL T
NAK	None	025	021	CTRL U
SYN	None	026	022	CTRL V
ETB	None	027	023	CTRL W
CAN	None	030	024	CTRL X
EM	None	031	025	CTRL Y
SUB	None	032	026	CTRL Z
ESC	Begins Command Seq.	033	027	CTRL [● ESC ● SHIFT ESC ● CTRL ESC
FS	None	034	028	CTRL
GS	None	035	029	CTRL _
RS	None	036	030	CTRL ,
US	None	037	031	CTRL -
SP	Space	040	032	SPACE BAR

**CTRL denotes control key.

NP denotes keys appearing on numeric pad as well as keyboard.

NAME OR MNEMONIC	ACTION TAKEN BY PRINTER	ASCII CODE (OCTAL)	DECIMAL EQUIVALENT	KEY(S) PRESSED TO GENERATE
Exclamation	Prints !	041	033	SHIFT! OR CTRL SHIFT!
Quotation Mark	Prints "	042	034	SHIFT" OR CTRL SHIFT"
Number Sign	Prints #	043	035	SHIFT# OR CTRL SHIFT#
Dollar Sign	Prints \$	044	036	SHIFT\$ OR CTRL SHIFT\$
Percent Sign	Prints %	045	037	SHIFT% OR CTRL SHIFT%
Ampersand	Prints &	046	038	SHIFT& OR CTRL SHIFT&
Apostrophe	Prints '	047	039	SHIFT' OR CTRL SHIFT/
Open Parenthesis	Prints (050	040	SHIFT(OR CTRL SHIFT(
Close Parenthesis	Prints)	051	041	SHIFT) OR CTRL SHIFT)
Asterisk	Prints *	052	042	SHIFT* OR CTRL SHIFT*
Plus Sign	Prints +	053	043	SHIFT+ OR CTRL SHIFT+
Comma	Prints ,	054	044	, OR CTRL,
Hyphen (Minus Sign)	Prints -	055	045	- OR CTRL-
Period (Decimal Point)	Prints .	056	046	. OR CTRL.(NP)
Slash	Prints /	057	047	/ OR CTRL/
Zero	Prints 0	060	048	0 OR CTRL 0(NP)
One	Prints 1	061	049	1 OR CTRL 1(NP)
Two	Prints 2	062	050	2 OR CTRL 2(NP)
Three	Prints 3	063	051	3 OR CTRL 3(NP)
Four	Prints 4	064	052	4 OR CTRL 4(NP)
Five	Prints 5	065	053	5 OR CTRL 5(NP)
Six	Prints 6	066	054	6 OR CTRL 6(NP)
Seven	Prints 7	067	055	7 OR CTRL 7(NP)
Eight	Prints 8	070	056	8 OR CTRL 8(NP)
Nine	Prints 9	071	057	9 OR CTRL 9(NP)
Colon	Prints :	072	058	SHIFT : OR CTRL SHIFT:
Semicolon	Prints ;	073	059	; OR CTRL;
Less Than	Prints <	074	060	SHIFT < OR CTRL SHIFT<
Equal Sign	Prints =	075	061	= OR CTRL=
Greater Than	Prints >	076	062	SHIFT > OR SHIFT>
Question Mark	Prints ?	077	063	SHIFT? OR CTRL SHIFT?
Commercial At	Prints @	100	064	SHIFT@ OR CTRL SHIFT@
A	Prints A	101	065	SHIFT A
B	Prints B	102	066	SHIFT B
C	Prints C	103	067	SHIFT C
D	Prints D	104	068	SHIFT D
E	Prints E	105	069	SHIFT E
F	Prints F	106	070	SHIFT F
G	Prints G	107	071	SHIFT G
H	Prints H	110	072	SHIFT H
I	Prints I	111	073	SHIFT I
J	Prints J	112	074	SHIFT J
K	Prints K	113	075	SHIFT K
L	Prints L	114	076	SHIFT L
M	Prints M	115	077	SHIFT M
N	Prints N	116	078	SHIFT N
O	Prints O	117	079	SHIFT O
P	Prints P	120	080	

NAME OR MNEMONIC	ACTION TAKEN BY PRINTER	ASCII CODE (OCTAL)	DECIMAL EQUIVALENT	KEY(S) PRESSED TO GENERATE
Q	Prints Q	121	081	SHIFT Q
R	Prints R	122	082	SHIFT R
S	Prints S	123	083	SHIFT S
T	Prints T	124	084	SHIFT T
U	Prints U	125	085	SHIFT U
V	Prints V	126	086	SHIFT V
W	Prints W	127	087	SHIFT W
X	Prints X	130	088	SHIFT X
Y	Prints Y	131	089	SHIFT Y
Z	Prints Z	132	090	SHIFT Z
Opening Bracket	Prints [133	091	[
Back Slash	Prints \	134	092	\
Close Bracket	Prints]	135	093]
Circumflex	Prints ^	136	094	^
Underline	Prints _	137	095	SHIFT _
Accent Grave	Prints `	140	096	`
a	Prints a	141	097	A
b	Prints b	142	098	B
c	Prints c	143	099	C
d	Prints d	144	100	D
e	Prints e	145	101	E
f	Prints f	146	102	F
g	Prints g	147	103	G
h	Prints h	150	104	H
i	Prints i	151	105	I
j	Prints j	152	106	J
k	Prints k	153	107	K
l	Prints l	154	108	L
m	Prints m	155	109	M
n	Prints n	156	110	N
o	Prints o	157	111	O
p	Prints p	160	112	P
q	Prints q	161	113	Q
r	Prints r	162	114	R
s	Prints s	163	115	S
t	Prints t	164	116	T
u	Prints u	165	117	U
v	Prints v	166	118	V
w	Prints w	167	119	W
x	Prints x	170	120	X
y	Prints y	171	121	Y
z	Prints z	172	122	Z
Open Baroque Parenthesis	Prints {	173	123	{
Vertical Mark Parenthesis	Prints }	174	124	SHIFT }
Close Baroque Parenthesis	Prints }	175	125	SHIFT }
TILDE	Prints ~	176	126	SHIFT ~
DELETE	None	177	127	DEL • SHIFT DEL • CTRL DEL • CTRL SHIFT DEL

This page intentionally left blank.

APPENDIX B

INTERNATIONAL CHARACTER SETS

There are seven 96-symbol character sets available with your DASHER LP2 or TP2 printer. They correspond to standard ASCII code specifications in the following seven countries: France, Germany, Spain, Sweden, the United Kingdom, the United States and Denmark.

Each character is defined by a 7-bit ASCII code. Control codes, 000-037 octal are not printed. The codes from 040-177 octal define the 96-symbol character set. The dot-matric patterns your printer produces for each code are shown on the following pages. We illustrate the American font in its entirety. However, of the remaining six fonts, we provide only those patterns which differ from the American font.

AMERICAN USAGE

040_g

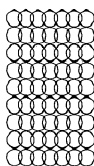

041_g

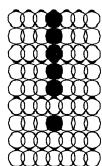

042_g

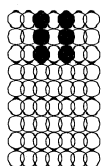

043_g

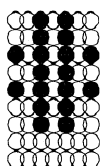

044_g

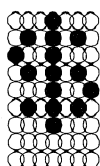

045_g

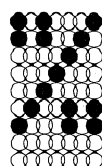

046_g

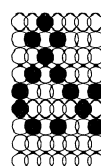

047_g

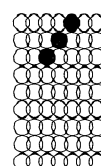

050_g

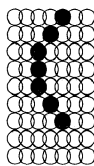

051_g

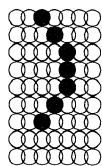

052_g

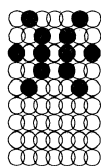

053_g

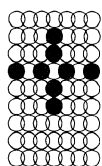

054_g

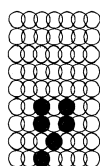

055_g

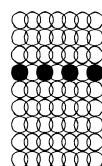

056_g

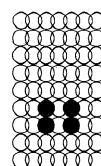

057_g

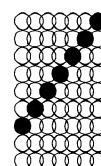

060_g

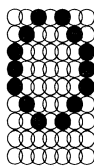

061_g

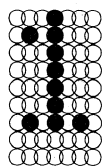

062_g

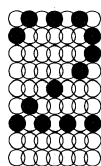

063_g

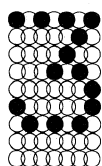

064_g

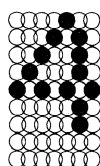

065_g

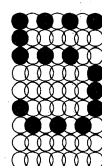

066_g

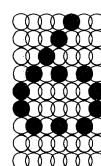

067_g

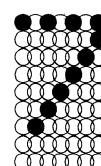

070_g

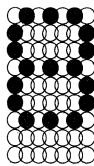

071_g

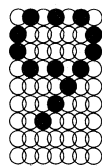

072_g

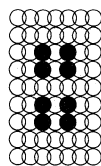

073_g

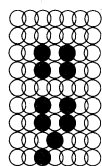

074_g

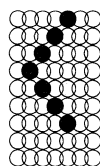

075_g

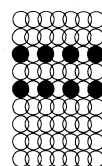

076_g

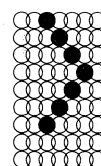

077_g

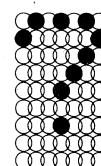

100_g

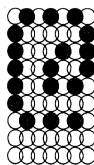

101_g

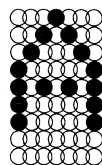

102_g

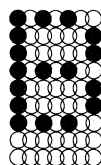

103_g

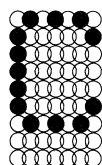

104_g

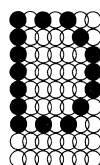

105_g

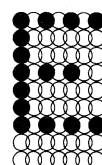

106_g

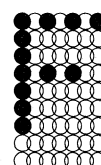

107_g

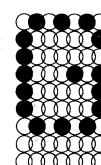

110_g

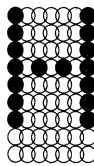

111_g

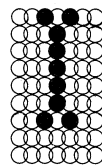

112_g

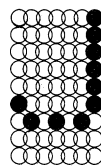

113_g

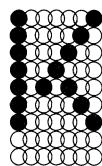

114_g

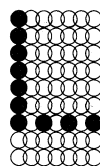

115_g

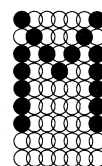

116_g

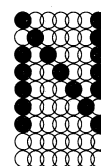

117_g

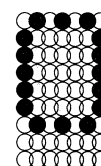

AMERICAN USAGE

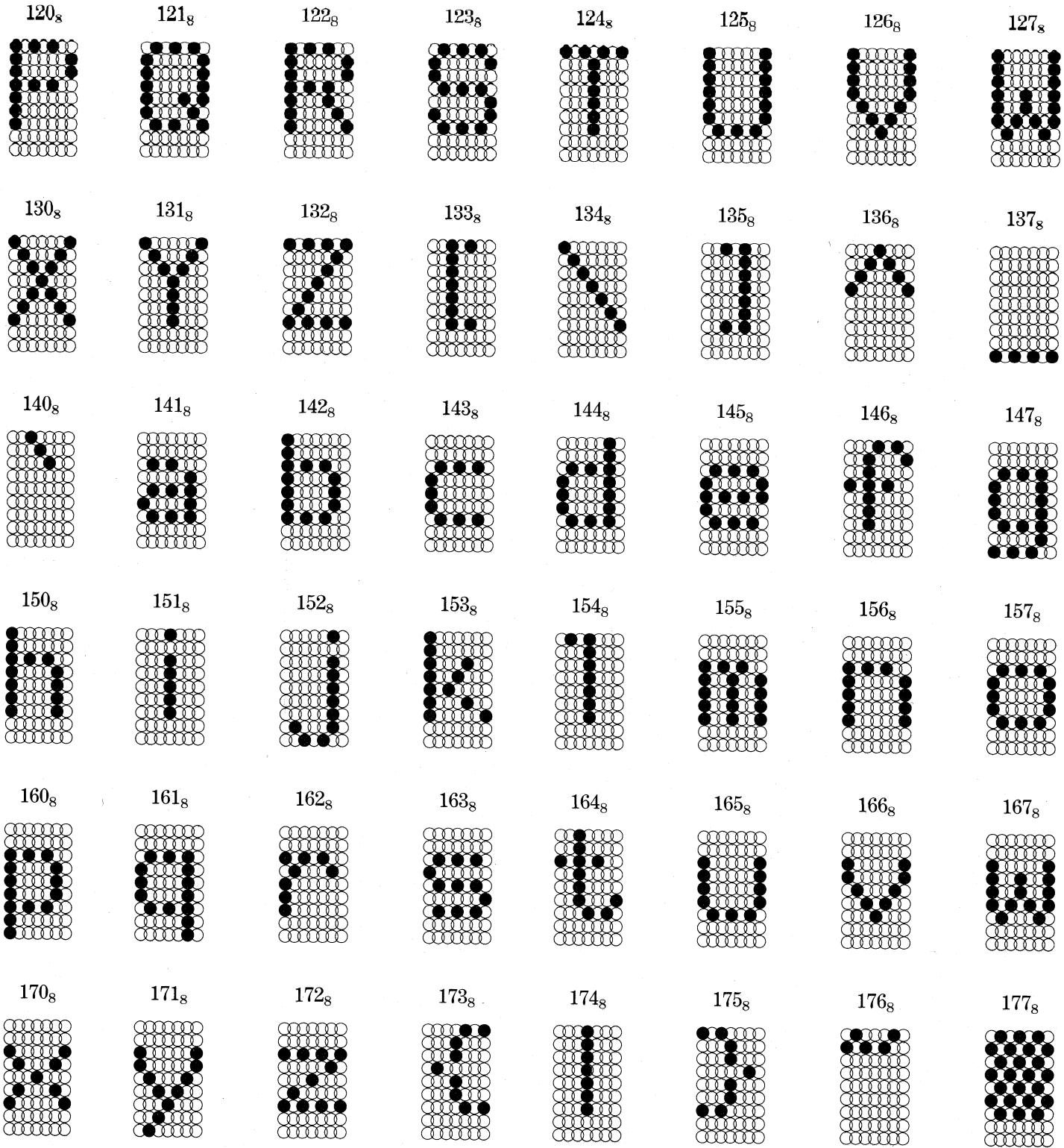

FRENCH USAGE

043_g

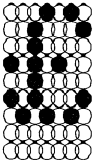

100_g

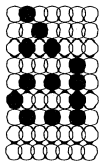

133_g

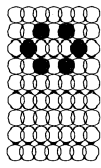

134_g

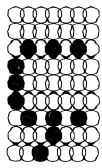

135_g

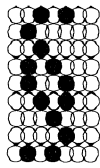

173_g

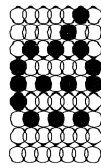

174_g

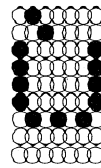

175_g

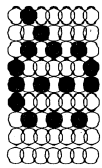

GERMAN USAGE

100_g

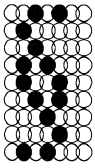

133_g

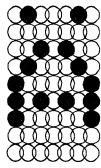

134_g

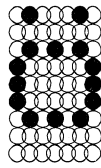

135_g

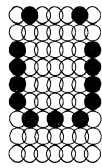

173_g

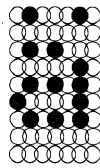

174_g

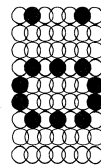

175_g

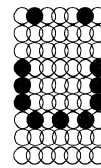

176_g

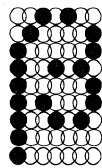

SPANISH USAGE

134_g

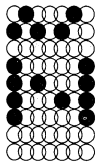

174_g

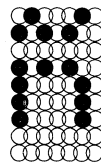

BRITISH USAGE

043_g

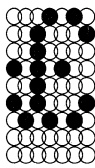

136_g

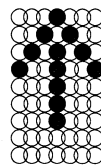

176_g

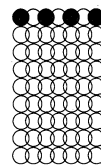

SWEDISH/FINNISH USAGE

044_g

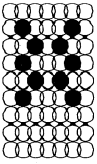

100_g

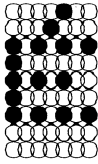

133_g

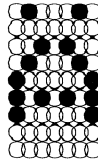

134_g

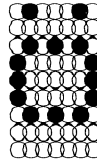

135_g

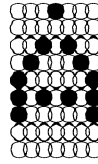

136_g

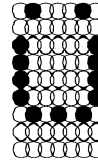

140_g

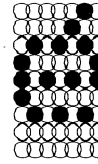

173_g

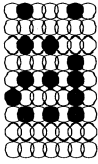

174_g

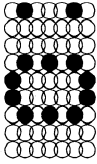

175_g

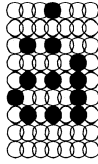

176_g

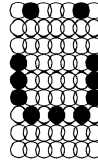

DANISH/NORWEGIAN USAGE

044_g

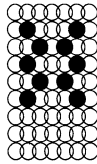

100_g

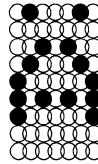

133_g

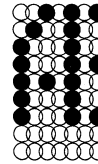

134_g

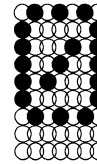

135_g

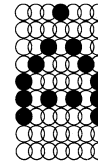

136_g

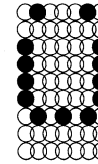

140_g

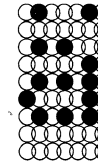

173_g

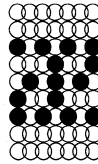

174_g

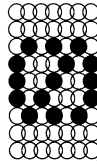

175_g

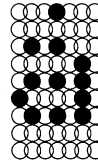

176_g

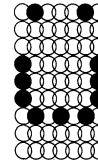

SALES AND SERVICE OFFICES

Alabama: Birmingham
Arizona: Phoenix, Tucson
Arkansas: Little Rock
California: El Segundo, Fresno, Palo Alto, Sacramento, San Diego, San Francisco, Santa Ana, Santa Barbara, Van Nuys
Colorado: Englewood
Connecticut: North Branford
Florida: Ft. Lauderdale, Orlando, Tampa
Georgia: Norcross
Idaho: Boise
Illinois: Peoria, Schaumburg
Indiana: Indianapolis
Kentucky: Louisville
Louisiana: Baton Rouge
Maryland: Baltimore
Massachusetts: Springfield, Wellesley, Worcester
Michigan: Southfield
Minnesota: Richfield
Missouri: Kansas City, St. Louis
Nevada: Las Vegas
New Hampshire: Nashua
New Jersey: Cherry Hill, Wayne
New Mexico: Albuquerque
New York: Buffalo, Latham, Melville, Newfield, New York, Rochester, Syracuse, White Plains
North Carolina: Charlotte, Greensboro
Ohio: Columbus, Dayton, Brooklyn Heights
Oklahoma: Oklahoma City, Tulsa
Oregon: Portland
Pennsylvania: Blue Bell, Carnegie
Rhode Island: Rumford
South Carolina: Columbia
Tennessee: Knoxville, Memphis
Texas: Austin, Dallas, El Paso, Ft. Worth, Houston
Utah: Salt Lake City
Virginia: McLean, Norfolk, Richmond, Salem
Washington: Kirkland
West Virginia: Charleston
Wisconsin: West Allis

Australia: Melbourne, Victoria
France: Le Plessis Robinson
Italy: Milan, Padua, Rome
The Netherlands: Rijswijk
New Zealand: Auckland, Wellington
Sweden: Gothenburg, Malmoe, Stockholm
Switzerland: Lausanne, Zurich
United Kingdom: Birmingham, Dublin, Glasgow, London, Manchester
West Germany: Filderstadt, Frankfurt, Hamburg, Munich, Ratingen, Rodelheim

DG-04976

MANUFACTURER'S REPRESENTATIVES & DISTRIBUTORS

Argentina: Buenos Aires
Costa Rica: San Jose
Ecuador: Quito
Egypt: Cairo
Finland: Helsinki
Greece: Athens
Hong Kong: Hong Kong
India: Bombay
Indonesia: Jakarta
Iran: Tehran
Israel: Givatayim
Japan: Tokyo
Jordan: Amman
Korea: Seoul
Kuwait: Kuwait
Lebanon: Beirut
Malaysia: Kuala Lumpur
Mexico: Mexico City
Nicaragua: Managua
Nigeria: Lagos, Ibadan
Norway: Oslo
Peru: Lima
Philippine Islands: Manila
Puerto Rico: Hato Rey
Saudi Arabia: Riyadh
Singapore: Singapore
South Africa: Johannesburg, Pretoria
Spain: Barcelona, Bilbao, Madrid, San Sebastian, Valencia
Taiwan: Taipei
Thailand: Bangkok
Uruguay: Montevideo
Venezuela: Maracaibo

ADMINISTRATION, MANUFACTURING RESEARCH AND DEVELOPMENT

Massachusetts: Cambridge, Framingham, Westboro, Southboro
Maine: Westbrook
New Hampshire: Portsmouth
California: Anaheim, Sunnyvale
North Carolina: Research Triangle Park, Johnston County
Hong Kong: Kowloon, Tai Po
Thailand: Bangkok

Data General Users Group

Installation Membership Form

Name _____ Position _____ Date _____

Company, Organization or School _____

Address _____ City _____ State _____ Zip _____

Telephone: Area Code _____ No. _____ Ext. _____

1. Account Category

- OEM
 End User
 System House
 Government

5. Mode of Operation

- Batch (Central)
 Batch (Via RJE)
 On-Line Interactive

2. Hardware

M/600
 C/350, C/330, C/300
 S/250, S/230, S/200
 S/130
 AP/130
 CS Series
 N3/D
 Other NOVA
 microNOVA
 Other _____
 (Specify) _____

Qty. Installed	Qty. On Order

6. Communications

- RSTCP CAM
 HASP 4025
 RJE80 Other
 SAM

Specify _____

7. Application Description

○ _____

3. Software

- AOS RDOS
 DOS RTOS
 SOS Other

Specify _____

8. Purchase

From whom was your machine(s) purchased?

- Data General Corp.
 Other
 Specify _____

4. Languages

- Algol Assembler
 DG/L Interactive
 Cobol Fortran
 ECLIPSE Cobol RPG II
 Business BASIC PL/1
 BASIC Other

Specify _____

9. Users Group

Are you interested in joining a special interest or regional Data General Users Group?

○ _____

CUT ALONG DOTTED LINE

FOLD

FOLD

FOLD

FOLD



NO POSTAGE
NECESSARY
IF MAILED
IN THE
UNITED STATES

BUSINESS REPLY MAIL
FIRST CLASS PERMIT NO. 26 SOUTHBORO, MA. 01772

Postage will be paid by addressee:

 **Data General**

ATTN: Users Group Coordinator
4400 Computer Drive
Westboro, MA 01580

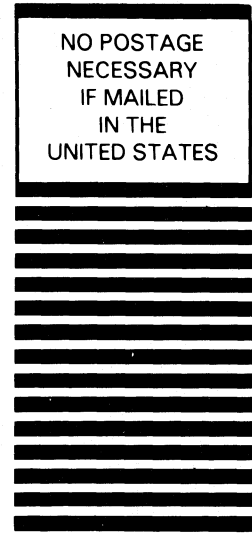

Engineering Publications Comment Form

Please help us improve our future publications by answering the questions below. Use the space provided for your comments.

Title: _____

Document No. _____

CUT ALONG DOTTED LINE

Yes	No		
<input type="checkbox"/>	<input type="checkbox"/>	Is this manual easy to read?	<input type="radio"/> You (can, cannot) find things easily. <input type="radio"/> Other: <input type="radio"/> Language (is, is not) appropriate. <input type="radio"/> Technical terms (are, are not) defined as needed.
		In what ways do you find this manual useful?	<input type="radio"/> Learning to use the equipment <input type="radio"/> To instruct a class. <input type="radio"/> As a reference <input type="radio"/> Other: <input type="radio"/> As an introduction to the product
<input type="checkbox"/>	<input type="checkbox"/>	Do the illustrations help you?	<input type="radio"/> Visuals (are, are not) well designed. <input type="radio"/> Labels and captions (are, are not) clear. <input type="radio"/> Other:
<input type="checkbox"/>	<input type="checkbox"/>	Does the manual tell you all you need to know? What additional information would you like?	
<input type="checkbox"/>	<input type="checkbox"/>	Is the information accurate? (If not please specify with page number and paragraph.)	

Name: _____ Title: _____

Company: _____ Division: _____

Address: _____ City: _____

State: _____ Zip: _____ Telephone: _____ Date: _____

FOLD

FOLD

FOLD

FOLD



NO POSTAGE
NECESSARY
IF MAILED
IN THE
UNITED STATES

BUSINESS REPLY MAIL
FIRST CLASS PERMIT NO. 26 SOUTHBORO, MA. 01772

Postage will be paid by addressee:

 **Data General**

ATTN: Users Group Coordinator
4400 Computer Drive
Westboro, MA 01580

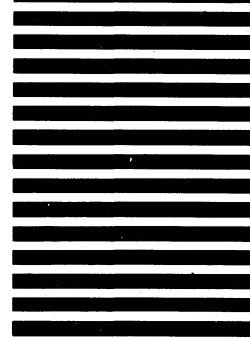

FOLD

FOLD

STAPLE

STAPLE

FOLD

FOLD



NO POSTAGE
NECESSARY
IF MAILED
IN THE
UNITED STATES

BUSINESS REPLY MAIL
FIRST CLASS PERMIT NO. 26 SOUTHBORO, MA. 01772

Postage will be paid by addressee:

 **Data General**

ATTN: ENGINEERING PUBLICATIONS

2706 Montopolis Drive
Austin, TX 78741

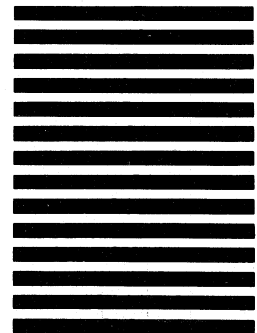

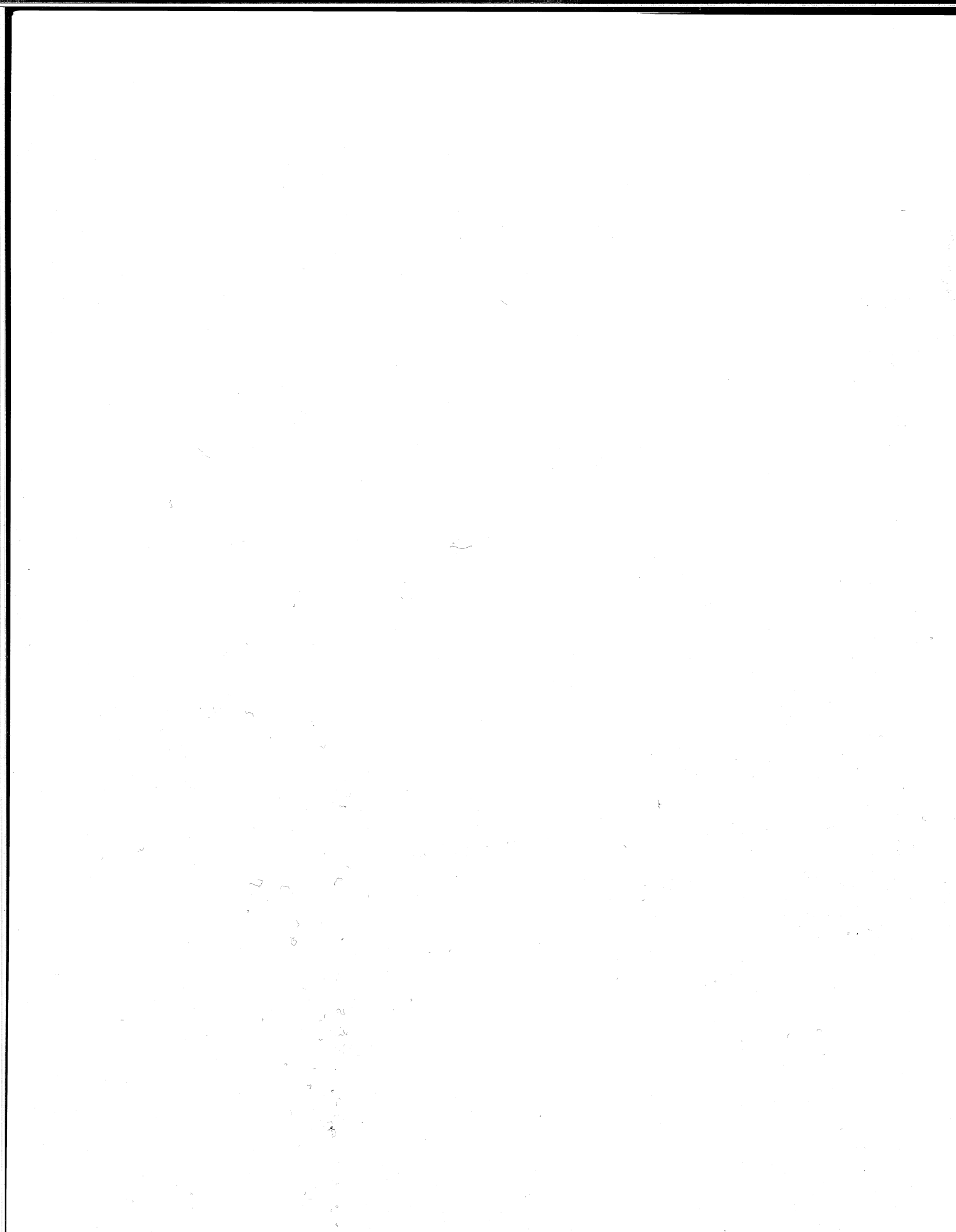



Data General Corporation, Westboro, Massachusetts 01581