

THIS DRAWING AND SPECIFICATIONS HEREIN ARE THE PROPERTY OF DATA GENERAL CORPORATION AND SHALL NOT BE REPRODUCED OR COPIED OR USED IN WHOLE OR IN PART AS THE BASIS FOR MANUFACTURE OR SALE OF ITEMS WITHOUT WRITTEN PERMISSION.

REVISIONS				
REV	DESCRIPTION	DRFTG	APP BY	DATE
00	RELEASED PER EC # 1241	PSS		

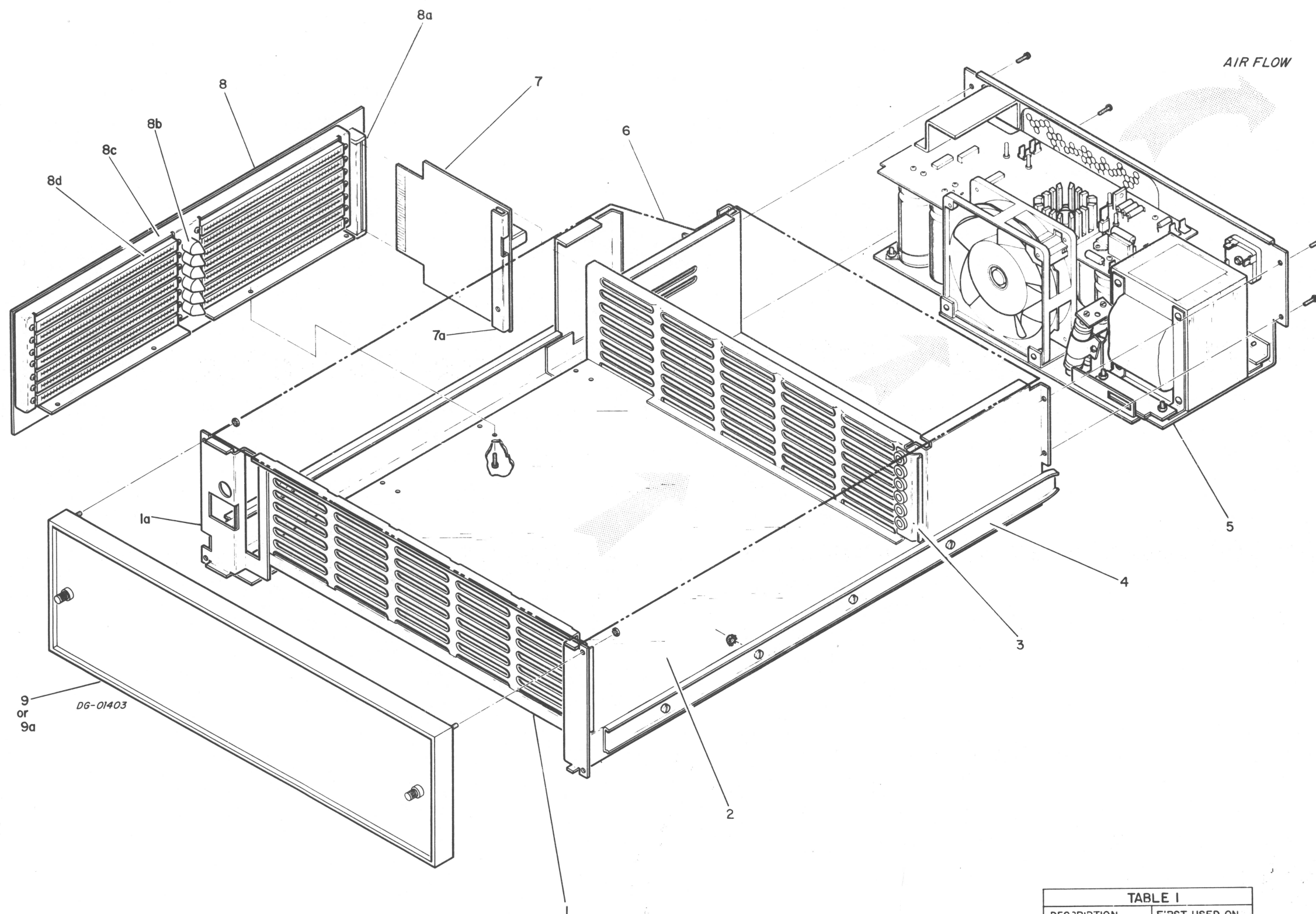

ITEM	QTY	DESCRIPTION	PART NO
9	1	ASSY EXPANSION PANEL (BLU)	005 006260
or 9a	4	SCREW PHH PNH SCDP	106 000062
	1	ASSY EXPANSION PANEL (ORN)	005 000410
	4	KEPS NUT 6-32	106 000256
8	1	ASSY PCB BACK PANEL	005 000413
8a	1	CONN. 26 POS'N (REF)	111 000079
8b	6	GUIDE CENTER	002 000035
8c	1	FRAME CONNECTOR	002 000224
8d	14	CONNECTOR CONTACT PC	111 000073
	28	SCREW, SEMS 4-40x3/8	106 000280
7	1	ASSY PCB RESISTOR (DUMMY)	005 000372
7a	1	BRACKET RESISTOR BOARD	002 000285
6	1	COVER, NOVA 800/1200 EXP.	002 000359
	15	SCREW, F. H. 4-40x1/4	106 000128
5	1	ASSY MAIN P/S +5V 800/1200	005 001928
or 5a	1	ASSY P/S SGL +5V 50HZ 800/1200	005 003717
REF		IPL ASSY MAIN P/S +5V	016 000194
	4	SCREW, SEMS 6-32x3/8	106 000078
4	2	SLIDE ACCURIDE 21"	123 000040
	8	SCREW, PHH 8-32x5/16	106 000316
	8	KEPS NUT 8-32	106 000255
3	1	ASSY CONN BAY	005 003679
	1	PLATE GUIDE, REAR	002 000216
	1	FASTENER P/C NOVA 800/1200	002 000245
	1	SUBASSY P/S & CONN BAY	002 000361
	6	WASHER FINISH NYLON	106 000027
	6	SCREW PHH FLH SLFTPG #6x1/4	106 000702
2	1	BASE CARD RACK	002 000219
1	1	ASSY, FRONT GUIDE PLATE	005 003678
	1	PLATE, GUIDE FRONT	002 000217
	1	BRACKET, CONS ATCH 800/1200	002 000244
	1	FASTENER PC NOVA 800/1200	002 000245
	6	WASHER FINISH NYLON	106 000027
	6	SCREW PHH FLH SLFTPG #6x1/4	106 000702
1a	1	BRACKET SUPPORT LOCK-SWITCH	002 000239

DESCRIPTION	FIRST USED ON
7 SLOT EXP 8I24	005 000408
7 SLOT EXP 50Hz	005 003713
7 SLOT EXP 8I24	005 006517
7 SLOT EXP 50Hz	005 006518

ORN {
BLU {

UNLESS OTHERWISE SPECIFIED USE D.G.C. SPECIFICATION 108-000028 FOR TOLERANCES AND WORKMANSHIP REQUIREMENTS

DRAWN: *[Signature]* 11/11/75
CHECKED: *[Signature]* 10/75
ENGINEER: *[Signature]*
APPROVED: *[Signature]*

MATERIAL: *[Signature]*
FINISH: *[Signature]*

FIRST USED ON: SEE TABLE I
SCALE: *[Signature]*

DATA GENERAL CORPORATIC
SOUTH BORO, MASSACHUSETTS 01772

TITLE:
**MECH IPL
NOVA 800/1200
EXPANSION CHASSIS**

SIZE: D CODE: 016 DRAWING NUMBER: 000197 REV: 00

BRUNING 40-526 20411