

THIS DRAWING AND SPECIFICATIONS HEREIN ARE THE PROPERTY OF DATA GENERAL CORPORATION AND SHALL NOT BE REPRODUCED OR COPIED OR USED IN WHOLE OR IN PART AS THE BASIS FOR MANUFACTURE OR SALE OF ITEMS WITHOUT WRITTEN PERMISSION.

| REVISIONS |  |             |        |               |
|-----------|--|-------------|--------|---------------|
| REV.      | DESCRIPTION                            | DRFTG.      | APP BY | DATE          |
| 01        | REVISED PER MKD PRINT                  | CHS         |        | 11/19/70      |
| 02        | REV PER ECO 117 SHEET 3                | RHS         |        | 11/16/70      |
| 03        | REV PER ECO 138 SHEET 1                | RHS         |        | 12/2/70       |
| 04        | REV PER ECO 148 SHEETS 2-8             | RHS         |        | 1/4/71        |
| 05        | REV PER ECO #198, 209                  | RHS         |        | 2/19/71       |
| 06        | ADD REF. DESIG. PER ECO #366           | RHS         |        | 4/15/71       |
| 07        | ECO 266, 299, 365, 413, 447, 562 + 575 | RHS         |        | 10/14/71      |
| 14        | REV. PER ECO # 992                     | RHS         |        | 9/29/72       |
| 15        | REV. PER ECO # 1060                    | RHS         |        | 7/27/72       |
| 16        | ECO # 1328                             | R.W.C.      |        | 12-12-73      |
| 17        | ECO # 2129                             | R.W.C.      |        | 12-12-73      |
|           | <b>ECO # 2658</b>                      | <b>F.M.</b> |        | <b>5-9-74</b> |

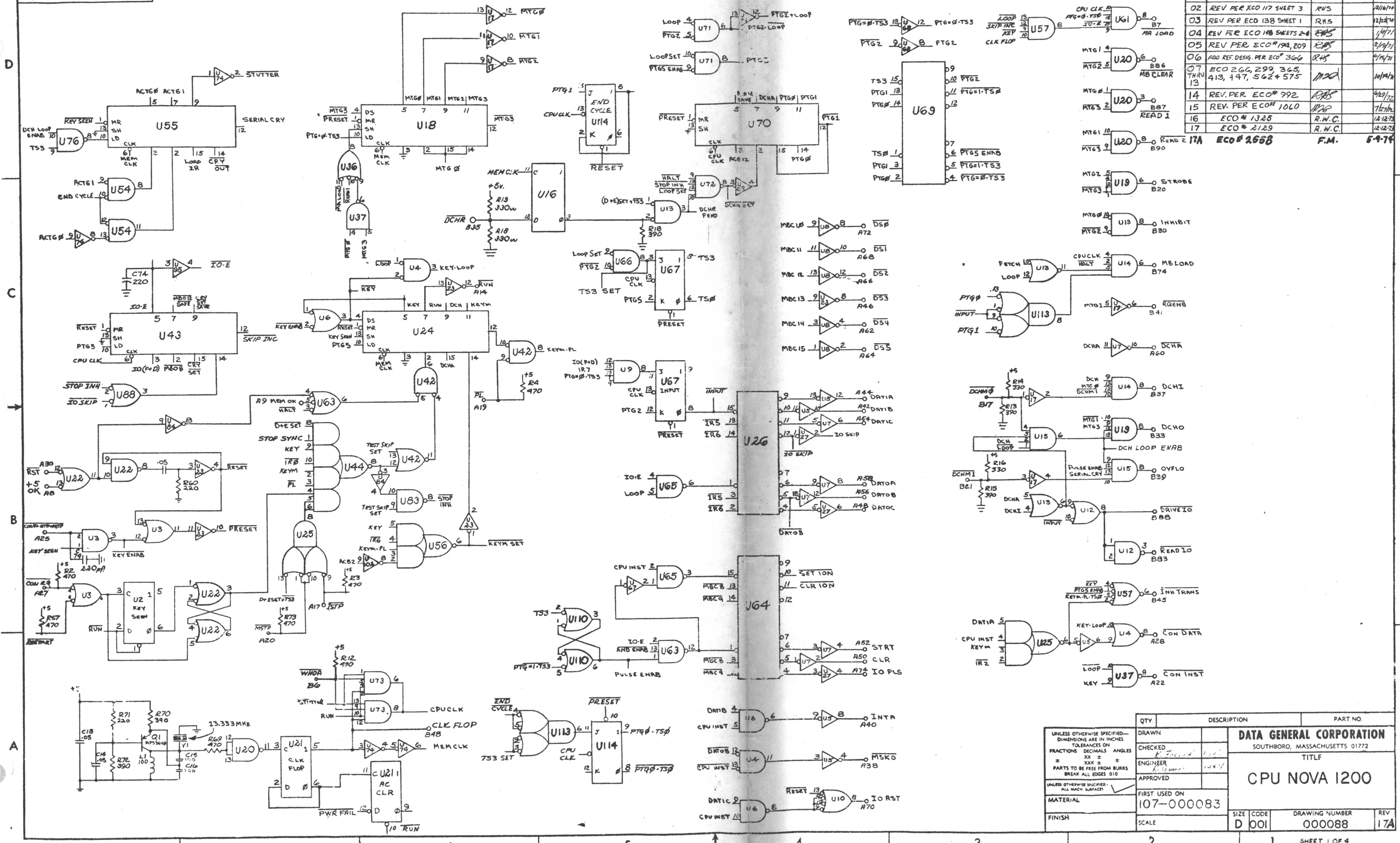

| QTY. | DESCRIPTION   | PART NO. |
|------|---|----------|
|      | UNLESS OTHERWISE SPECIFIED—DIMENSIONS ARE IN INCHES TOLERANCES ON FRACTIONS DECIMALS ANGLES |          |
|      | XX ±  |          |
|      | PARTS TO BE FREE FROM BURRS BREAK ALL EDGES 010   |          |
|      | UNLESS OTHERWISE SPECIFIED—ALL MACH SURFACES  |          |
|      | MATERIAL  |          |
|      | FINISH  |          |
|      | SCALE   |          |
|      | SIZE CODE   |          |
|      | DRAWING NUMBER  |          |
|      | REV   |          |

|                |  |  |                                |  |  |
|----------------|--|--|--------------------------------|--|--|
| DRAWN          |  |  | DATA GENERAL CORPORATION       |  |  |
| CHECKED        |  |  | SOUTHBORO, MASSACHUSETTS 01772 |  |  |
| ENGINEER       |  |  | TITLE                          |  |  |
| APPROVED       |  |  | CPU NOVA 1200                  |  |  |
| FIRST USED ON  |  |  | 107-000083                     |  |  |
| SCALE          |  |  | D 001                          |  |  |
| DRAWING NUMBER |  |  | 000088                         |  |  |
| REV            |  |  | 17A                            |  |  |

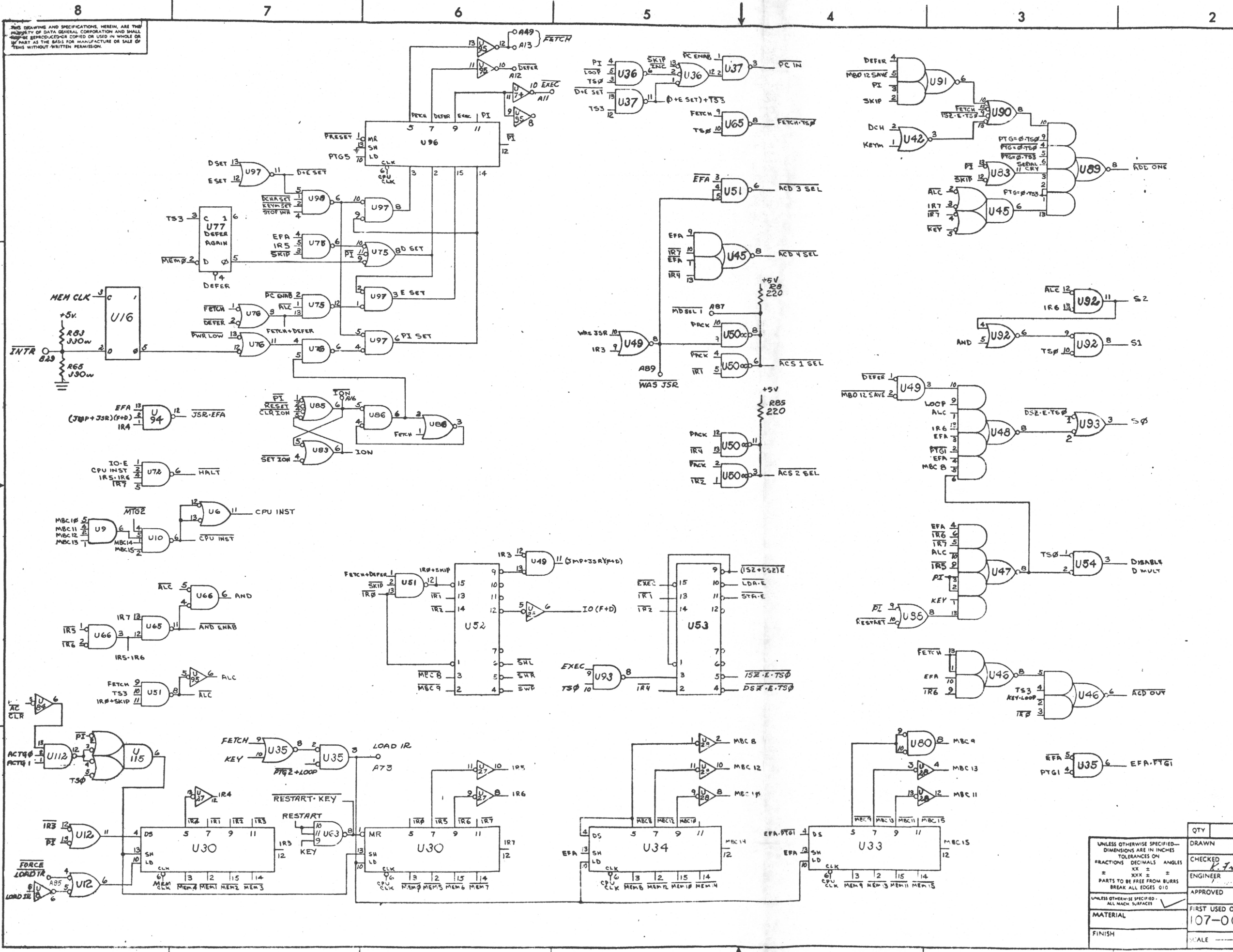

| REVISIONS |                               |       |        |          |
|-----------|-------------------------------|-------|--------|----------|
| REV       | DESCRIPTION                   | DRFTG | APP BY | DATE     |
| 01        | REV PER SHEET 1               | RHS   |        | 11/19/70 |
| 02        | REV PER ECO 117 SHEET 3       | RHS   |        | 12/14/70 |
| 03        | REV PER ECO 158 SHEET 1       | RHS   |        | 1/24/71  |
| 04        | REV PER ECO 148               | RHS   |        | 1/24/71  |
| 05        | REV PER ECO # 194,209         | RHS   |        | 2/19/71  |
| 06        | ADD REV. DESIG. PER ECO # 366 | RHS   |        | 4/14/71  |
| 14        | REV PER ECO # 992             | RHS   |        | 6/10/71  |

|   |               |                  |   |       |  |   |         |                  |  |          |  |  |          |  |  |               |            |  |       |  |
|---|---------------|------------------|---|-------|--|---|---------|------------------|--|----------|--|--|----------|--|--|---------------|------------|--|-------|--|
| QTY   | DESCRIPTION   | PART NO          |   |       |  |   |         |                  |  |          |  |  |          |  |  |               |            |  |       |  |
| <table border="1"> <tr> <td>UNLESS OTHERWISE SPECIFIED—<br/>DIMENSIONS ARE IN INCHES<br/>FRACTIONS DECIMALS ANGLES<br/>=   XXX   =   =</td> <td>DRAWN</td> <td></td> </tr> <tr> <td>PARTS TO BE FREE FROM BURRS<br/>BREAK ALL EDGES 0.10</td> <td>CHECKED</td> <td><i>K. J. ...</i></td> </tr> <tr> <td></td> <td>ENGINEER</td> <td></td> </tr> <tr> <td></td> <td>APPROVED</td> <td></td> </tr> <tr> <td></td> <td>FIRST USED ON</td> <td>107-000083</td> </tr> <tr> <td></td> <td>SCALE</td> <td></td> </tr> </table> |               |                  | UNLESS OTHERWISE SPECIFIED—<br>DIMENSIONS ARE IN INCHES<br>FRACTIONS DECIMALS ANGLES<br>=   XXX   =   = | DRAWN |  | PARTS TO BE FREE FROM BURRS<br>BREAK ALL EDGES 0.10 | CHECKED | <i>K. J. ...</i> |  | ENGINEER |  |  | APPROVED |  |  | FIRST USED ON | 107-000083 |  | SCALE |  |
| UNLESS OTHERWISE SPECIFIED—<br>DIMENSIONS ARE IN INCHES<br>FRACTIONS DECIMALS ANGLES<br>=   XXX   =   =   | DRAWN         |                  |   |       |  |   |         |                  |  |          |  |  |          |  |  |               |            |  |       |  |
| PARTS TO BE FREE FROM BURRS<br>BREAK ALL EDGES 0.10   | CHECKED       | <i>K. J. ...</i> |   |       |  |   |         |                  |  |          |  |  |          |  |  |               |            |  |       |  |
|   | ENGINEER      |                  |   |       |  |   |         |                  |  |          |  |  |          |  |  |               |            |  |       |  |
|   | APPROVED      |                  |   |       |  |   |         |                  |  |          |  |  |          |  |  |               |            |  |       |  |
|   | FIRST USED ON | 107-000083       |   |       |  |   |         |                  |  |          |  |  |          |  |  |               |            |  |       |  |
|   | SCALE         |                  |   |       |  |   |         |                  |  |          |  |  |          |  |  |               |            |  |       |  |
| <b>DATA GENERAL CORPORATION</b><br>SOUTHBORO, MASSACHUSETTS 01772<br>TITLE<br><h2 style="text-align: center;">CPU NOVA 1200</h2>  |               |                  |   |       |  |   |         |                  |  |          |  |  |          |  |  |               |            |  |       |  |
| MATERIAL  | FINISH        |                  |   |       |  |   |         |                  |  |          |  |  |          |  |  |               |            |  |       |  |
| SIZE  | CODE          | D 001            |   |       |  |   |         |                  |  |          |  |  |          |  |  |               |            |  |       |  |
| DRAWING NUMBER  | REV           | 000088 174       |   |       |  |   |         |                  |  |          |  |  |          |  |  |               |            |  |       |  |

THIS DRAWING AND SPECIFICATIONS, HEREIN, ARE THE PROPERTY OF DATA GENERAL CORPORATION AND SHALL NOT BE REPRODUCED OR COPIED OR USED IN WHOLE OR IN PART AS THE BASIS FOR MANUFACTURE OR SALE OF ITEMS WITHOUT WRITTEN PERMISSION.

| REVISIONS |                               |       |        |          |
|-----------|-------------------------------|-------|--------|----------|
| REV       | DESCRIPTION                   | DRFTG | APP BY | DATE     |
| 01        | REVISED PER MKD PRINT         | RHS   |        | 11/19/70 |
| 02        | REVISED PER ECO 117           | RHS   |        | 12/14/70 |
| 03        | REV PER ECO 138 SHEET 1       | RHS   |        | 12/21/70 |
| 04        | REV PER ECO 148               | RHS   |        | 1/14/71  |
| 05        | REV PER ECO # 199,209         | RHS   |        | 2/19/71  |
| 06        | ADD REF. DESIG. PER ECO # 366 | RHS   |        | 4/15/71  |
| 14        | REV PER ECO # 992             | RHS   |        | 6/10/72  |

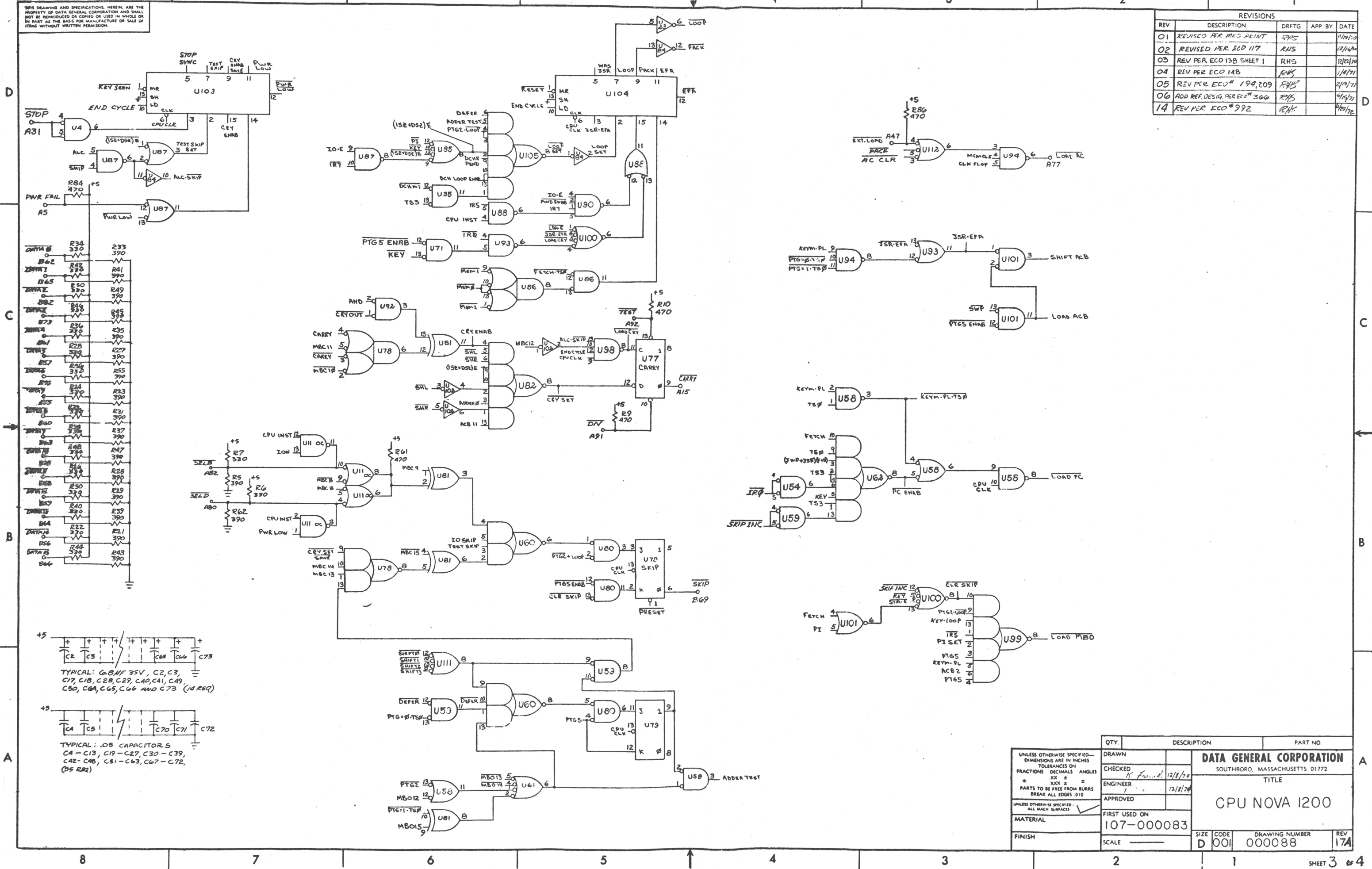

| QTY. | DESCRIPTION   | PART NO. |
|------|---------------|----------|
|      | DRAWN         |          |
|      | CHECKED       |          |
|      | ENGINEER      |          |
|      | APPROVED      |          |
|      | FIRST USED ON |          |
|      | MATERIAL      |          |
|      | FINISH        |          |

|   |  |
|---|--|
| UNLESS OTHERWISE SPECIFIED—<br>DIMENSIONS ARE IN INCHES<br>TOLERANCES ON<br>FRACTIONS DECIMALS ANGLES<br>XX ± ° |  |
| PARTS TO BE FREE FROM BURRS<br>BREAK ALL EDGES 010  |  |
| UNLESS OTHERWISE SPECIFIED—<br>ALL MACH SURFACES  |  |
| MATERIAL  |  |
| FINISH  |  |

|               |  |      |  |
|---------------|--|------|--|
| DRAWN         |  | DATE |  |
| CHECKED       |  | DATE |  |
| ENGINEER      |  | DATE |  |
| APPROVED      |  | DATE |  |
| FIRST USED ON |  | DATE |  |
| MATERIAL      |  | DATE |  |
| FINISH        |  | DATE |  |

|                          |      |                                |     |
|--------------------------|------|--------------------------------|-----|
| DATA GENERAL CORPORATION |      | SOUTHBORO, MASSACHUSETTS 01772 |     |
| TITLE                    |      |                                |     |
| CPU NOVA 1200            |      |                                |     |
| SIZE                     | CODE | DRAWING NUMBER                 | REV |
| D                        | 001  | 000088                         | 17A |

THIS DRAWING AND SPECIFICATIONS, HEREIN, ARE THE PROPERTY OF DATA GENERAL CORPORATION AND SHALL NOT BE REPRODUCED OR USED IN WHOLE OR IN PART AS THE BASIS FOR MANUFACTURE OR SALE OF ITEMS WITHOUT WRITTEN PERMISSION.

| REVISIONS |                             |       |        |          |
|-----------|-----------------------------|-------|--------|----------|
| REV.      | DESCRIPTION                 | DRFTG | APP BY | DATE     |
| 01        | REVISED PER MKD PRINT       | RHS   |        | 11/9/70  |
| 02        | REV PER ECO #17 SHEET 3     | RHS   |        | 12/14/70 |
| 03        | REV PER ECO #138 SHEET 1    | RHS   |        | 12/29/70 |
| 04        | REV PER ECO #148            | RHS   |        | 1/19/71  |
| 05        | REV PER ECO #194, 209       | RHS   |        | 2/11/71  |
| 06        | ADD EYE, DESIG PER ECO #366 | RHS   |        | 4/13/71  |
| 14        | PER ECO #992                | RHS   |        | 4/29/72  |

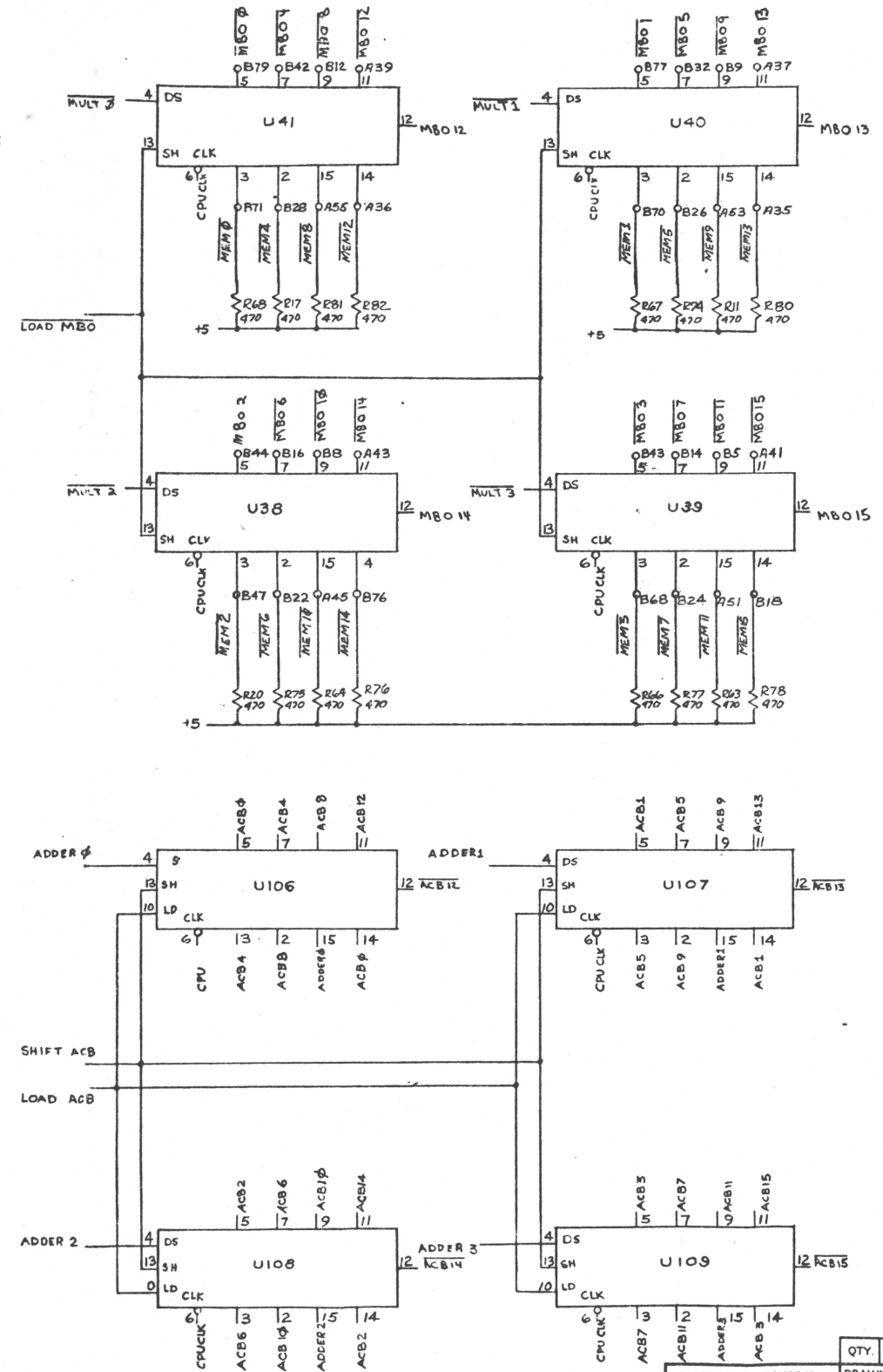
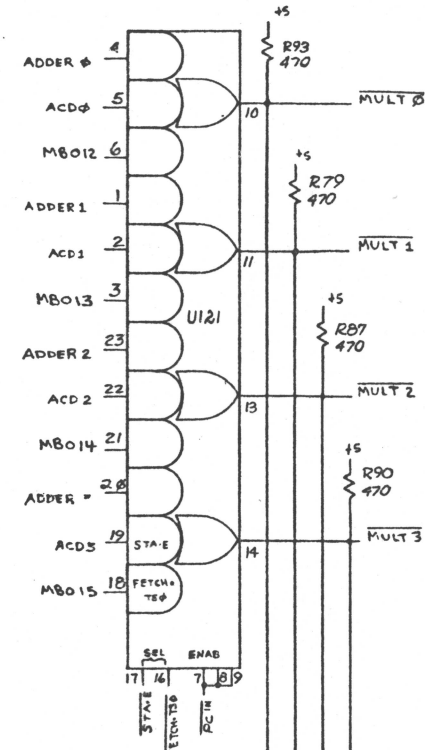
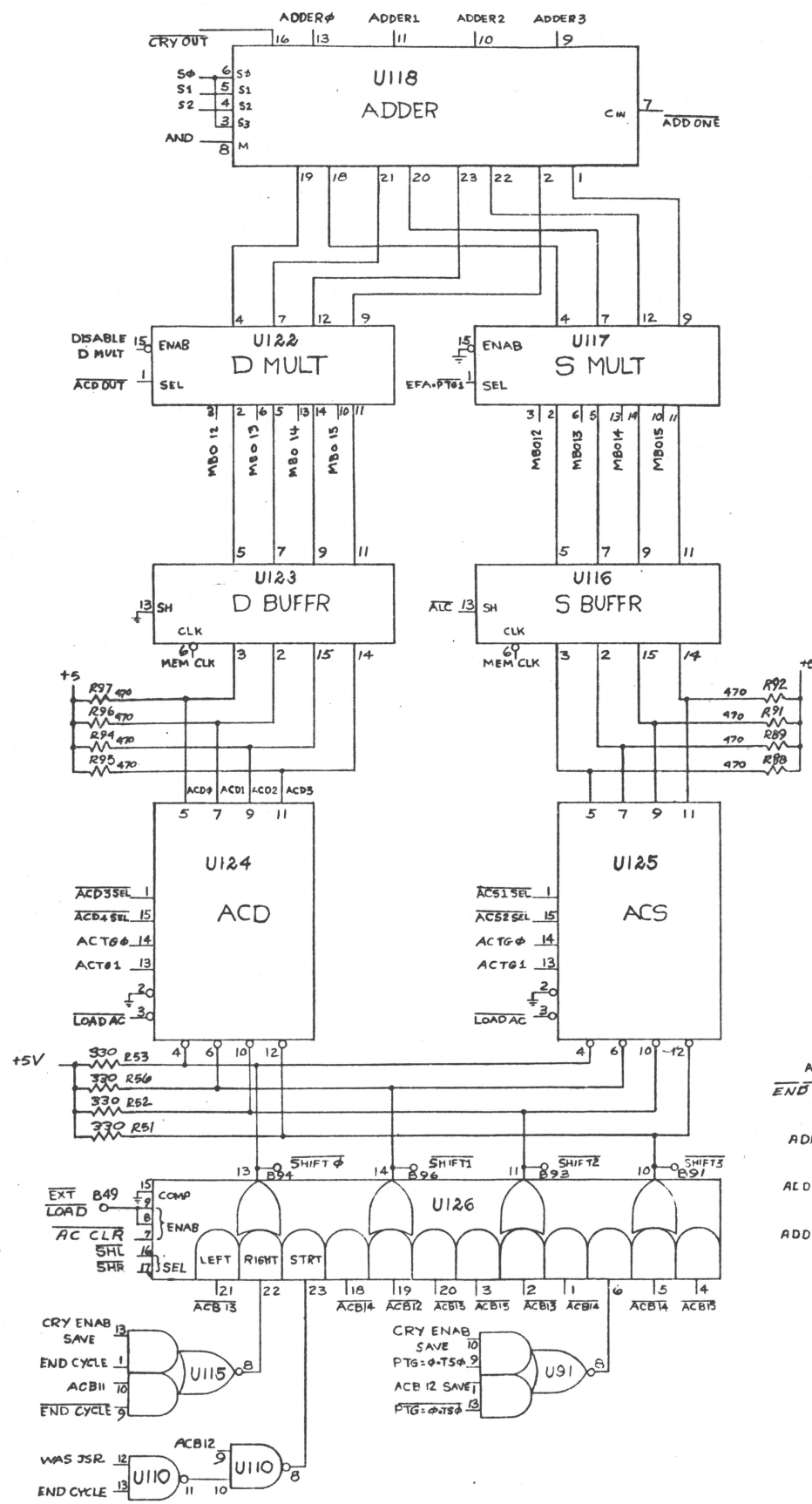

ALL CAPACITORS ARE IN MICROFARADS AND ALL RESISTORS ARE IN OHMS. 1/4 WATT, WITH 5% TOLERANCE UNLESS OTHERWISE SPECIFIED.

|          |               |            |
|----------|---------------|------------|
| QTY      | DESCRIPTION   | PART NO.   |
| DRAWN    | CHECKED       | ENGINEER   |
| APPROVED | FIRST USED ON | 107-000083 |
| MATERIAL | FINISH        | SCALE      |

|   |      |                |     |
|---|------|----------------|-----|
| <b>DATA GENERAL CORPORATION</b><br>SOUTHBORO, MASSACHUSETTS 01772 |      |                |     |
| TITLE   |      |                |     |
| <b>CPU NOVA 1200</b>  |      |                |     |
| SIZE  | CODE | DRAWING NUMBER | REV |
| D.001   |      | 000088         | 17A |