

THIS DRAWING AND SPECIFICATIONS HEREIN ARE THE PROPERTY OF DATA GENERAL CORPORATION AND SHALL NOT BE REPRODUCED OR COPIED OR USED IN WHOLE OR IN PART AS THE BASIS FOR MANUFACTURE OR SALE OF ITEMS WITHOUT WRITTEN PERMISSION.

REVISIONS				
REV.	DESCRIPTION	DRFTG	APP BY	DATE
00	RELEASED PER ECO-3852			

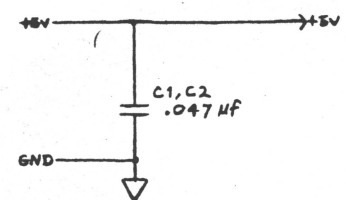
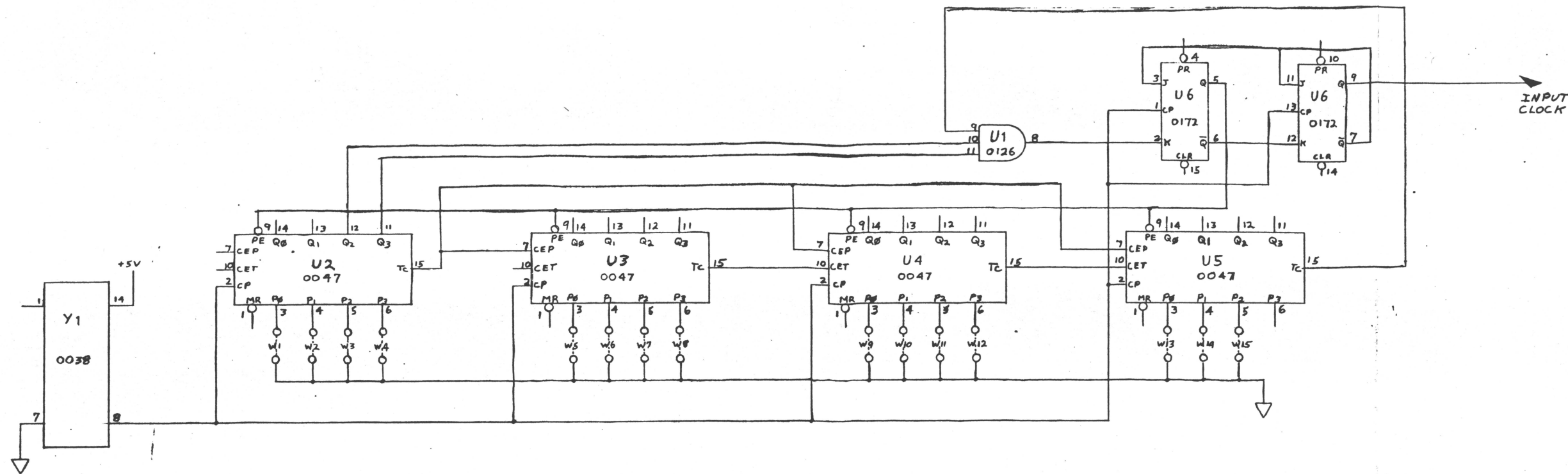

BAUD RATE	INSTALL JUMPERS
75	W8, W10, W13, W15
110	W7, W12, W13, W14
134.5	W5, W6, W7, W8, W9, W11, W12, W14
150	W7, W9, W12, W14
300	W6, W8, W11, W13
600	W5, W7, W10, W12
1200	W4, W6, W9, W11
1800	W5, W6, W7, W9, W10
2400	W3, W5, W8, W10
4800	W2, W4, W7, W9
7200	W3, W4, W5, W7, W8
9600	W1, W3, W6, W8

ARTWORK: 107000572		UNLESS OTHERWISE SPECIFIED USE D.G.C. SPECIFICATION 108-000028 FOR TOLERANCES AND WORKMANSHIP REQUIREMENTS		QTY	DESCRIPTION	PART NO
REV	SCHEMATIC REV(S)	DRAWN	WA Powers	20	SEP 75	DATA GENERAL CORPORATION SOUTHBORO, MASSACHUSETTS 01772
01	00	CHECKED	Z & J	10-29	75	
		ENGINEER	WA Powers	20	SEP 75	TITLE
		APPROVED	[Signature]	10/21		BASIC I/O BOARD
		FIRST USED ON	4010			JUMPER SELECTABLE TTY CLOCK
		FINISH		SIZE	CODE	DRAWING NUMBER
		SCALE		D		001 000 890

DRAWING 40-135 (20/71)