

Release Notice for

In-Service Diagnostics Release 9.0 x86 R4.20

085-001571-00

November, 1997

LICENSED MATERIAL - PROPERTY OF DGC

DATA GENERAL PROPRIETARY DIAGNOSTICS

This diagnostic material contains information which is proprietary and confidential to Data General Corporation (DGC) and is the exclusive property of DGC. Unless there is a license agreement executed by DGC under which DGC has identified this diagnostic material and expressly licensed you, this diagnostic material is provided to you in trust under the "Data and Proprietary Rights" clause of your agreement with DGC only for use by or on behalf of DGC (including its subsidiary companies) during the warranty period and under any contract maintenance period. This diagnostic material, in whole or in part, is not to be reproduced by any means nor made available to any third party. You agree to return this diagnostic material to DGC at the end of the above identified period(s) or destroy this diagnostic material and, upon request, notify DGC in writing of such destruction.

This copyright notice does not constitute or evidence publication or public disclosure.

RESTRICTED RIGHTS LEGEND RESTRICTED RIGHTS: Use, duplication or disclosure by the U.S. Government is subject to restrictions as set forth in subparagraph (c) (1) (ii) of the Rights in Technical Data and Computer Software clause of Defense Federal Acquisition Regulation (DFAR) 252.227-7013 and in subparagraphs (a) through (d) of the Commercial Computer Software Restricted Rights clause at Federal Acquisition Regulations (FAR) 52.227-19, whichever may apply.

Data General Corporation
4400 Computer Drive
Westborough, MA 01580

Unpublished - rights reserved under the copyright laws of the United States and all other countries.

Copyright © Data General Corporation, 1995-1997

All Rights Reserved

In-Service Diagnostics Release 9.0 x86 R4.20 Release Notice

1. Introduction	3
2. Product Description	3
3. Documentation	3
3.1 Manuals.....	3
3.2 Documentation Changes	3
4. Software	4
4.1 Media.....	4
4.2 Organization/Files.....	4
5. In-Service Diagnostics (ISD).....	4
5.1 Environment.....	4
5.2 Prerequisites.....	4
5.3 User Requirements.....	4
5.4 Enhancements and Changes.....	4
5.4.1 Enhancements	4
5.4.2 Changes	5
5.5 Notes and Warnings.....	6
5.5.1 Notes	6
5.5.2 Warnings.....	8
5.6 CD-ROM Pre-Installation/Installation Instructions	9
5.6.1 CD-ROM Pre-Installation of ISD	9
5.6.2 Installation of ISD.....	9
5.6.3 CD-ROM Removal.....	10
5.7 Installation of ISD into a Clustered System.....	10
5.8 Loading instructions for AV/Alert patch files bundled with ISD.....	11
6. Using In-Service Diagnostics (ISD).....	12
6.1 Starting the Test Manager (TM)	12
6.2 ISD Suggested Test Setups	12
6.3 ISD Functionality.....	13
6.3.1 Test Selection	13
6.3.2 Logs	13
6.3.3 Leaving the User Interface.....	13
6.3.4 ISD Man Pages	13
6.4 ISD Sync/Async Test.....	13
6.4.1 Async PTC Test Requirements.....	14
6.4.2 Sync Test Requirements	15
6.4.3 Async Loopback Plugs	15
6.4.4 Sync Loopback Plugs.....	16
6.5 Network Test Configuration	17
6.6 Operating System Configuration Requirements.....	17
7. APPENDIX A	19
7.1 Software Socket Test Exerciser	19

1. Introduction

This release notice supports the release of the In-Service Diagnostic Media which contains the following parts:

<u>Part Description</u>	<u>Part Number</u>
1. DG/UX R4.20 x86 In-Service Diagnostics Release Notice	085-001571-00
2. In-Service Diagnostics Release 9.0 x86 R4.20 Release Media	See section 4 of this release notice

2. Product Description

The following is a brief description of each of the major components released with the In-Service Diagnostics Release 9.0 x86 R4.20 package.

A diagnostic support system with a set of diagnostics and tools for maintaining the Intel based product family. This diagnostic package contains the ISD test manager, the ISD User Interface, Core Component Test, Memory Test, Async Test, Sync Test, Disk Test, Network Test, File System Test, Tape Test, UNIX Domain Socket Test, Network Socket(TCP/IP)Test, and Jukebox Test.

3. Documentation

3.1 Manuals

This section contains information on the titles and changes in the In-Service Diagnostics Release 9.0 x86 R4.20 documentation set. Please refer to Key Chart below for symbols used to show manuals that are new, revised, or have had no changes since the last master release of these diagnostics.

Status	Part Number	Name
-	014-002512-01	Using AViiON Diagnostics and the AV/Alert Diagnostic Support System

Status Key: A = "Added", R = "Revised", - = "No Change"

3.2 Documentation Changes

Page 3-15 of the Field guide should have Figure 3-13's description changed from Core Component Level-1 Status Report to: Async Level-1 Status Report

Page 3-17 Eliminate or disregard 3.2.2 and 3.2.4. These tests are no longer included in the ISD test suite.

See APPENDIX A for additional changes to the Field guide.

4. Software

4.1 Media

The Diagnostic Media Package contains the In-Service Diagnostics Release 9.0 x86 R4.11

Media parts designated below is for the CD-ROM media package.

<u>Status</u>	<u>Part Number</u>	<u>Description</u>
R	068-003261-00	CD-ROM

Status Key: A = "Added", R = "Revised", - = "No Change"

4.2 Organization/Files

The following list outlines the files contained on the media along with a brief description of what is in each file.

<u>File</u>	<u>Contents</u>
1	DGISD table of contents
3	DGISD usr directory files
4	DGISD opt directory files
5	DGISD usr/opt directory files

5. In-Service Diagnostics (ISD)

5.1 Environment

The In-Service Diagnostics Release 9.0 x86 R4.20 should be used on all Data General Intel based AViiON servers, that run DG/UX R4.20.

To run ISD the system must be powered up with DG/UX running at init 1 or higher. ISD will normally be loaded on system disks. New releases of ISD are located via SysAdm. The distribution of ISD for the AV 20000 system will be CD-ROM only .

This release requires that at least DG/UX R4.20 to be installed on the machine.

This release is **NOT** for use with DG/UX R4.10, R4.11, or R4.12.

5.2 Prerequisites

Hardware Requirements: Intel x86 based system only, that run DG/UX R4.20.

5.3 User Requirements

The ISD User Interface Program(UI) can be brought up in either Motif or ASCII mode. If the non-X windows ASCII mode is used, it is recommended that the user be adept at using the sysadm feature of DG/UX or the Interface Description Interpreter(IDI), this will be helpful in traversing through the layers of the ISD interface. See the IDI man pages for navigation tips.

5.4 Enhancements and Changes

5.4.1 Enhancements

- Memory Test enhancements:
 - * Modified to support up to 32 GigaBytes of memory on NUMA systems. This support includes systems with

non-contiguous blocks/nodes. Support for UMA systems remains at a maximum of 4 GigaBytes. Thus for every one GigaByte (or part of) of free memory space at the time ISD's Test Manager (TM) is started, a copy of the memory test will be produced.

- Core Components Test enhancements:
 - * The ISD Core Components Test (Core_Components) was enhanced to support up to 32 GigaBytes of memory on NUMA systems. Memory of various sizes on each block/node has been accounted for, as well as contiguous and non-contiguous blocks/nodes within the system.
- Socket Test enhancements:
 - * The ISD Socket Test (isdsw_inet_sckt) was enhanced to provide two additional level 1 statuses and one level 2 status information. In addition to the existing level 1 status, "Subtest Summary", the statuses, "Summary by Interface" and "Snapshot servers/client" were added. See Appendix A for additional information.
 - * "Summary by Interface" provides statistics for each interface identified on the system. These statistics include; the IP Address, the total bytes read and written by each interface, and the number of bytes read and written on the current test pass for each interface.
 - * The "Snapshot servers/client" provides; the port number, Connection Count, name, and address of each server, and the port number, name, and address of each client.
 - * The level 2 status "tcpip_subt" displays the following information for each server: Number of accept or connect errors, Number of bytes written by the server, the interface name and address for the server, and the socket type used. The level 2 status "tcpip_subt" also displays the following information for each client: Number of choose server retries, Number of accept or connect retries, Number of accept or connect errors, Number of bytes read by the client, the interface name and address for the client, and the socket type used for each client.
 - * The socket test should be used for initial Multi-Connected LAN (MCL) support. Additional test support will be provided via the Network test in a later release of ISD.
- Disk Test enhancements:
 - * The disk test (disk_insc(0,7) etc.) was modified to provide additional support for fibre channel controllers and the disk drives attached to them.
- Network Test enhancements:
 - * The Network Test (network_*) was modified to mark any network cards found in the system but not configured to be not available. This prevents tests that require the network card to be configured from being run and then failing as a result of the card not being configured.
 - * The Network test was modified to support longer device names.

5.4.2 Changes

- Compatibility problem when running ISD 8.0 or greater on a system with DG/UX R4.20 with MU01 Pass 3.1. Because of a change in MU01 Pass 3.1, a system may panic when trying to run ISD 8.0 or greater. The problem was fixed in MU01 Pass 3.2, and was not an issue with MU01 Pass 3.0 and earlier. See NSQA-000041878-0 for further information.
- ISD fix for File System Test soft errors causing a fatal error and core. This fix addresses an issue of ISD reporting a soft error during the file system test with an uninitialized value that sometimes worked, and other times caused a fatal error or core to occur. See NSQA-00042327-0 for further information.
- ISD fix for systems hanging when one or more tests failed to start without an error while "First failure of a test terminates all tests" is set as the failure behavior. This fix addresses the issue of several tests getting to the

“ready” state while one or more tests get left in the starting state due to a failure of a test. This problem is resolved in ISD 9.0. A work around for earlier versions of ISD is to set the failure behavior to any other choice except the “First failure of a test terminates all tests”. See NSQA-000041790-0 for further information.

- The Socket Subsystem Exerciser (isdsw_sckt) has been changed to be deselected by default.

5.5 Notes and Warnings

5.5.1 Notes

- Performance Monitor (PM)

Setting the CPU performance parameter to a targeted value means that ISD will only run when the system performance parameter is below that targeted value. For example, if ISD's CPU utilization is set to 40%, then ISD will only run when the system is below this targeted value. Thus if the system is already running at 35% CPU utilization, then ISD will run and contribute only 5% more to the CPU utilization, thereby reaching the targeted goal of 40%. There is no way to set ISD to a specific percentage, for example, a way to set ISD to 4% constant CPU utilization. Although this does not permit setting specific utilization targets, it does allow a means to minimize the load impact ISD contributes to a user's system.

A word of caution about setting PM resource usage to 100%. ISD will be unrestrained in its use of system resources at 100%, which can produce effects that seem to be problems but are not. The following example shows how setting the CPU parameters to 100% could lead to seemingly problematic system behavior.

Suppose a user sets up an ISD test run of the Tape Test and Memory Test with the PM parameters CPU, IO, and MEM set to 100%. On a lightly loaded system, the response time to the user will appear to be normal. A `sar -u 5 5` will show the system running mostly at 100% cpu utilization but the user response will be fine. If the same thing is done for a system where there are added file systems, lots of extra disks, complex network, etc., the system response will be very unacceptable. The tests may start taking soft errors as they are timing out before reporting in with the test manager. This is "normal" or expected behavior as too much is asked of the system - its overloaded. You will have to find the correct balance for your system which is resource and configuration dependent. With the performance parameters, you can use ISD to stress the system stand-alone or use it as a background low profile system exerciser.

- Time Outs

Time Outs can appear to be problems. Time Outs for tape can be quite long. Time Outs in a large network configuration can take a long time. The Time Outs make the user interface appear to not be starting but it may only be running through a number of device Time Outs. The answer as to what is a long time and how long should one wait cannot be specifically pinned down. The answer is configuration dependent.

- Device Recognition

Typically the ISD Test Manager daemon is run when the system is (re)started at system boot time or at an explicit init level change. If a device is brought on line after boot, the Test Manager will not have seen the device. The sizer will have to be re-run by selecting the resize ISD option from the ISD user interface(or stop and restart the TM in a prescribed way).

- Asynchronous Test

Typically the Test Manager daemon is already running, you **MUST** kill and restart it, or the Subtest will not be seen by the test. This behavior is due to the fact the controller is not enabled at the time the Test Manager tries to create the Subtest.

The subset names in status reports have been modified to make correspondence to line names in `/dev/async/line` more identifiable. Sample output captures:

Output from a CPAC subtest listing:

```

CPAC_1_cpac(pci(0),D,0) .CPAC:Line_0      : Selected
CPAC_1_cpac(pci(0),D,0) .CPAC:Line_1      : Selected
CPAC_1_cpac(pci(0),D,0) .CPAC:Line_2      : Selected
CPAC_1_cpac(pci(0),D,0) .CPAC:Line_3      : Selected
CPAC_1_cpac(pci(0),D,0) .CPAC:Line_4      :Deselected
CPAC_1_cpac(pci(0),D,0) .CPAC:Line_5      :Deselected
CPAC_1_cpac(pci(0),D,0) .CPAC:Line_6      :Deselected
CPAC_1_cpac(pci(0),D,0) .CPAC:Line_7      :Deselected
CPAC_1_cpac(pci(0),D,0) .CPAC:Line_8      :Deselected
CPAC_1_cpac(pci(0),D,0) .CPAC:Line_9      :Deselected
CPAC_1_cpac(pci(0),D,0) .CPAC:Line_A      :Deselected
CPAC_1_cpac(pci(0),D,0) .CPAC:Line_B      :Deselected
CPAC_1_cpac(pci(0),D,0) .CPAC:Line_C      :Deselected
CPAC_1_cpac(pci(0),D,0) .CPAC:Line_D      :Deselected
CPAC_1_cpac(pci(0),D,0) .CPAC:Line_E      :Deselected
CPAC_1_cpac(pci(0),D,0) .CPAC:Line_F      :Deselected

```

Output from a level 0 status:

```

In-Service Diagnostics release 7.1 x86 Nov 25 1996 Total Hard Errors:0
Current Time: Mon Mar 17 10:30:20 1997      Elapsed Time:          0.02:26

```

TEST NAME	PASSES	HARD ERRORS	SOFT ERRORS	STATUS
CPAC_1_cpac(pci (0),D,0)	244	0	0	running

```

In-Service Diagnostics release 7.1 x86 Nov 25 1996 Total Hard Errors:0
Current Time: Mon Mar 17 10:30:30 1997      Elapsed Time:          0.02:36

```

TEST NAME	PASSES	HARD ERRORS	SOFT ERRORS	STATUS
CPAC_1_cpac(pci (0),D,0)	259	0	0	running

Output from a level 1 status:

```

Level 1 status for CPAC_1_cpac(pci(0),D,0) Total Hard Errors: 0
Current Time: Mon Mar 17 10:30:50 1997      Elapsed Time:          0:02:46
Test is running

```

SUBTEST NAME	PASSES	HARD ERRORS	SOFT ERRORS
CPAC:Line_0	72	0	0
CPAC:Line_1	68	0	0
CPAC:Line_2	66	0	0
CPAC:Line_3	69	0	0

```

Level 1 status for CPAC_1_cpac(pci(0),D,0) Total Hard Errors: 0
Current Time: Mon Mar 17 10:30:50 1997      Elapsed Time:          0:02:56
Test is running

```

SUBTEST	HARD	SOFT
---------	------	------

NAME	PASSES	ERRORS	ERRORS
CPAC:Line_0	70	0	0
CPAC:Line_1	73	0	0
CPAC:Line_2	70	0	0
CPAC:Line_3	72	0	0

- Network Testing

LAN Testing on networks that have Virtual TermServer Controllers attached locally may cause Operating System outages or test failures. The network can be run in configurations that do not have VTC's on the same local network.

LAN errors are to be expected on busy networks and/or on controllers which use unreliable protocols.

- OpStar Jukeboxes

OpStar Jukeboxes will be unavailable if their JB scheduler is running. Consult OpStar documentation to shutdown OpStar. For example, the commands:

```
cd /
```

```
sh /etc/rc2id/s211.mmmmd stop
```

That will stop all the schedules and disable the OpStar file systems. If the Test Manager (TM) is already running, it will have to be restarted so that the jukeboxes appear available for testing.

5.5.2 Warnings

- ISD in General

Some errors may occur when ISD tries to do a MI call, in addition some inventory status may not be complete or accurate. All these issues do not threaten regular ISD functionality and will be addressed in the upcoming ISD.

Dynamic update status may cause the GUI interface to core. ISD recommends to use the ASCII version of ISD while this problem is being resolved.

- Network Test

Consider a network which has several nodes on it. There may be cases where DG/UX with ISD is running on one node and Windows NT is running on another node. If they are on the same subnet, current rev ISD Network Test may get errors of type fault code 08-14-xxxx. xxxx represents the error number returned by the system when the error occurred. These will be addressed with later revisions of ISD.

- Asynchronous Device Test

The Computone IntelliPort II board will be limited to a maximum of four lines that can safely be tested simultaneously. While testing with more lines is possible, consideration must be given to how ISD exercises the Computone ports in a systematic manner. The test is not just sending data over open lines. The test is opening each port, recording its settings, modifying the port settings, sending data, verifying the data sent is returned correctly, resetting the ports settings, and closing the port. Depending on system load, number of CPU's, port speed, etc., ISD may report time outs, these are reported as soft errors, in the context of the Asynchronous test. The performance experienced with other high end boards such as VDA should not be expected from the reduced cost Computone board.

- Core Components Test

On systems with 8 or less CPU's, if other applications which are CPU intensive are run concurrently with the ISD Core Components test, then the Core Components tests may appear to increment its pass count less frequently. This is expected behavior and is due to the nature of the test. Ideally, the Core Components Test should be run without any other CPU intensive applications running at the same time, in order to provide maximum test coverage.

- Starting the User Interface

On systems with very large configurations, particularly with a lot of Network cards, the User Interface (UI) may time out if it is started immediately after the `isd_tm` was started. This is due to the large number of devices that ISD is sizing in the system. Should this happen, the user should merely wait a moment before trying to invoke the UI again.

5.6 CD-ROM Pre-Installation/Installation Instructions

5.6.1 CD-ROM Pre-Installation of ISD

This section provides the steps required to register, create and mount your CD-ROM disk for installing ISD.

- Log in to your DG/UX system as root.
- Insert the ISD Diagnostics media in your CD-ROM drive.
- Register the CD-ROM device.
`admpdisk -o list`
`admpdisk -o register 'device address '`

*Notes:

1. change device path to appropriate designation.
 2. make sure to use single quotes when specifying the CD-ROM device.
- Make a directory (`/+release`, not the generic directory: `/cdrom` as stated in SysAdm) to mount the CD-ROM on.
`mkdir /+release`
 - Mount the CD-ROM disk.
`mount -o ro /dev/dsk/+release /+release`

The following is a brief set of instructions for installing the In-Service Diagnostics from CD-ROM. In this section the In-Service Diagnostics create a Logical Disk Partition and register your CD-ROM drive. While creating a Logical Disk Partition isn't required, it's good System Administration practice to create one when installing new software packages. Detailed installation instructions are included in the Customer Documentation: "Using AViiON Diagnostics and the AV/Alert Support System".

- Log in to your DG/UX system as root.
- Insert the ISD Diagnostics media in your CD-ROM drive.
- Should your system have In-Service Diagnostics running, it must be stopped prior to this installation. Stop the currently running In-Service Diagnostics by issuing the following command:
`/usr/sbin/init.d/rc.dgisd stop`

5.6.2 Installation of ISD

- a) Install the new release of ISD under SysAdm.

```
# sysadm install package
```

- b) Release Medium [`/dev/rmt/0`]

For CD-ROM the device will be `/+release/isd_9.0`

In-Service Diagnostics 9.0_x86_420 of xx/xx/xx from Data General Corporation Package Name(s): [all] newline
(xx/xx/xx indicates when the release was created)

You selected the following packages:

dgisd

Is this correct ? [yes] newline

(NOTE: Use the default values for the remainder of the prompted questions)

(NOTE: The following will be displayed on the screen during the installation process.)

Loading Package dgisd

Package load finished

Package setup for dgisd is complete

List file names while loading ? [no] newline

OK to perform operation ? [yes] newline

(NOTE: At this point in time the ISD installation is complete and the user can quit out of SysAdm)

- c) For additional information, please refer to the detailed instructions which are included in the "Using AViiON Diagnostics and the AV/Alert Support" manual.

5.6.3 CD-ROM Removal

This section provides the steps required to unmount, and deregister your CD-ROM disk after installing ISD. You will need to deregister the CD-ROM after Rebooting DG/UX in order to be able to remove the CD-ROM media from the CD-ROM drive.

- a. Shut down and reboot your DG/UX system.
- b. Log in to your DG/UX system as root.
- c. # umount /+release
- d. Deregister the CD-ROM device.
admpdisk -o list
admpdisk -o deregister 'device address'

*Notes:

1. change device path to appropriate designation.
2. make sure to use single quotes when specifying the CD-ROM device.

5.7 Installation of ISD into a Clustered System

These instructions will guide you through a normal cluster installation.

- a) Ensure that isd_tm is not running on any node in the cluster.
Issue a "ps -ef | grep tm" command, and if isd_tm shows up, issue a "dg_kill -SIGTERM isd_tm" command.
- b) Pick a node from which to perform the install.
This would be the one with the drive which the install media will be loaded. These instructions will make ISD runnable from any node in the cluster (provided it is running the same revision of DG/UX as the node you are installing from).
- c) Follow the pre-installation instructions for the appropriate ISD media (See sections 5.6.1 or 5.7.1).

After selecting to install the ISD package, you will get a Release Area: [PRIMARY] prompt. Select the area which corresponds to the /usr partition in use by your node (similar to R411MU01).

At the prompt for "which client to set up", choose ALL

If there is no partition currently set up for dgisd, then you will be prompted to allow creation of a partition. At the modify this info prompt, you should NOT use the default for the physical disk to be used! Instead, use a physical disk which is on the shared bus.

Use the default values for completing the remainder of the prompt questions during the installation.

- d) ISD is now installed on the node you ran install from. To complete the process, and make ISD runnable from

other nodes, type:

```
#admfilesystem -o unmount /usr/opt/dgisd
```

```
#admfilesystem -o mount /usr/opt/dgisd
```

5.8 Loading instructions for AV/Alert patch files bundled with ISD

You should be in run level 1 when loading this patch to avoid overwriting a program that is currently running. Before you load this patch, execute the following commands to stop the currently running SVCNMR and remote service daemons:

```
# /usr/sbin/init.d/rc.dgsserv stop
```

```
# /usr/sbin/init.d/rc.dgrmserv stop
```

- To load this patch from CD-ROM, perform the following steps.

- a) This section provides the steps required to register, create and mount your CD-ROM disk for installing svcnmr patches.

- Log in to your DG/UX system as root.
- Insert the ISD Diagnostics and Service Manager media in your CD-ROM drive
- Register the CD-ROM device.
admpdisk -o list
admpdisk -o register 'device address '
- Make a directory to mount the CD-ROM on.
- # mkdir /+release
- Mount the CD-ROM disk.
mount -o ro /dev/dsk/+release /+release

- b) Run sysadm loadpackage to install the patch, be sure to choose the appropriate path depending on the operating system revision level you are running for the Release Medium response.

```
/+release/svcnmr_R4.20_patch
```

This example assumes you want to load the latest R4.20 patch.

```
# sysadm loadpackage
Release Medium: [/dev/rmt/2] /+release/svcnmr_R4.20_patch
You selected the following package:
dgux_R4.20.p31
Correct?[yes]
Package Name(s): [all]
List file names while loading? [no]
OK to perform operation? [yes]
Loading DG/UX Operating System...
Loading package: <package name> .....
Package "<package name>" has been loaded.
Package load is finished.
The selected packages have been loaded.
```

- c) Unmount the CD-ROM file system:

This section provides the steps required to unmount, and deregister your CD-ROM disk after installing svcnmr patches. You will need to deregister the CD-ROM after Rebooting DGUX to be able to remove the CD-ROM media from the CD-ROM drive.

- Log into your DG/UX system as root and unmount the file:
#umount /+release
- Deregister the CD-ROM device:
admpdisk -o list

```
# admpdisk -o deregister 'device address'
```

- While still in the Package Menu, select "Set up" the package or exit sysadm and use sysadm setuppackage:

```
# sysadm setuppackage
Package Name(s): [all]
OK to perform operation? [yes]
Setting up dgux_R4.20.p31 in MY_HOST root.
Package dgux_R4.20.p31 has been successfully set up in MY_HOST root.
Package setup for dgux_R4.20.p31 is complete.
```

- See Chapter 15 of the Managing the DG/UX System manual for instructions on reconfiguring the system. Use sysadm newdgux to build and install a new kernel. You will want to reboot your system at this point. If you are a diskless server, your client kernels must be rebuilt or the new dgux.diskless in /usr/stand must be hard linked to the appropriate client's root area. The patch setup is now complete.

6. Using In-Service Diagnostics (ISD)

6.1 Starting the Test Manager (TM)

You must start the Test Manager daemon before you can start the ISD User interface. To start the Test Manager daemon, enter:

```
# isd_tm
```

It is only necessary to restart the Test Manager daemon upon installation, or when something abnormal occurs on the system.

To start the User Interface (GUI version), you must set the DISPLAY environment variable to the X11 display you wish to use. (NOTE: X11 must be installed on the system in order to use it.)

```
# DISPLAY=(my workstation):0.0
# export DISPLAY
```

You can now start the GUI user interface.

```
# isd_ui &
```

Or you can now start the ASCII user interface.

```
# isd_uia
```

Refer to the manual for more specific information.

6.2 ISD Suggested Test Setups

a) Customer environment, new machine, no applications loaded:

- 1) Run ISD with the standard default test selections listed by ISD and select the disk and tape tests.
- 2) Boost all three performance parameters to 100%.

b) Customer Environment, system under production load:

- 1) Run ISD with the standard default test selections listed by ISD.
- 2) Run with performance parameters at the default of 50% or less depending on system load.
- 3) Monitor closely with
#sar -u 5 5.
- 4) Set failure mode to terminate testing on the first failure.

c) Test, Development, or Manufacturing Environment (for use by Data General Field Engineering only):

- 1) Where test is desired on a configuration without applications running:
Run ISD with * for the test selections i.e. select all.
- 2) Add file system to make a total of 10 provided you have at least 5 disks, otherwise run with the default file systems. The number can vary depending on the number of disks and the disk load you wish to impose. You could have a 20 disk CLARiiON setup as a volume, or 20 which will vary the IO load markedly.
- 3) Prompt the disk tests for read/write mode.
- 4) Set failures to a failure mode of no termination.

6.3 ISD Functionality

6.3.1 Test Selection

To select, deselect, and control tests, use the Current Tests menu.

6.3.2 Logs

To view, search, and delete ISD logfiles, use the Logs menu.

6.3.3 Leaving the User Interface

- a) To leave the user interface, select the Files menu and then select the Exit option.
- b) To terminate the TM daemon, select the Files menu and then select kill TM option.

6.3.4 ISD Man Pages

For more detailed information, please refer to the following man pages entitled `isd_intro`, `isd_tm` and `isd_ui`.

6.4 ISD Sync/Async Test

General

Synchronous or Asynchronous Communications testing is comprised of Modem Signal loopback testing, and Data loopback testing.

Loopback

Since External Loopback, and PTC Internal Loopback requires operator intervention to install, these test cannot be run in Customer Mode.

Data Signal Test

Data Signal Test is accomplished via an internal loopback on the card, or an external loopback plug. Synchronous card testing is done with internal and external loopback plugs depending on the card. The following table indicates which plugs are used with various cards.

<u>Card</u>	<u>Model</u>	<u>Type</u>	<u>Loopback Type</u>
Cpac		Async	External
Sync	Vac/16	Async	External
	VDA/128	Async	External
	VDA/255	Async	External
Spac	PTC/1024	Async	Internal
		Sync	Internal

The Asynchronous Test for PTC requires special DG/UX setup and is run using ISD Prompting Mode. A special section is devoted to describing how to run this test. See section 6.2.1

Modem Signal Testing

The Modem Signal Testing applies to the Asynchronous Communications card and uses the same external plugs used in the Data Signal Test. This test generates the appropriate modem signals with data transfers. The Modem Signal Test is available in the ISD Prompting Mode.

6.4.1 Async PTC Test Requirements

The following describes in detail the setup procedures needed to execute the async PTC Internal Loopback test. Included is a sample vtc.addr file, along with a description of selective entries within the file needed for the setup and execution of the test.

There is a system file called vtc.addr that is located in /etc/tcload directory. This file controls which addresses need to be set for each PCIbus Terminal Controller PTC board in the system. The user MUST modify this file and then execute the system command "tcload -av" from the command line. It is very IMPORTANT that this gets done prior to starting the isd_tm daemon. There is a /etc/tcload/vtc.addr.proto file that can be copied and renamed to vtc.addr then modified per example supplied below. If an existing vtc.addr file is present, you may want to save it under another name.

The following steps contain instructions needed to successfully configure and execute ISD's testing of the PTC boards.

1. Save a copy of the existing /etc/tcload/vtc.addr file (if it exist).
2. Create a vtc.addr file by either using a copy of vtc.addr.proto, vtc.addr or from scratch.
3. Edit the vtc.addr file adding the lines that you want tested. Reference the sample vtc.addr file below and read the corresponding explanation of the entries that follows it.
4. Execute the system command "tcload -av" from the command line.
5. Start the ISD test manager daemon(isd_tm)
(Note: If isd_tm is already running you MUST kill it and restart, or the changes made to the vtc.addr file will not be seen by the test).

The following is a Sample "vtc.addr" file that has been modified to test 2 PTC boards using lines tty03/04, tty257/258 on controller 1, and tty1030/1031, tty1500/1501 on controller 2..

"vtc.addr" file contents begins after this line.

ISD sizing Controller 1

```
/dev/async/ctrl/spac(pci(0),C,0) 128.222.4.267 128.222.4.255 255.255.255.00 default
```

```
/dev/tty03 128.222.4.267@3000 telnetin
```

```
/dev/tty04 128.222.4.267@3000 telnetout
```

```
/dev/tty257 128.222.4.267@3002 telnetin
```

```
/dev/tty258 128.222.4.267@3002 telnetout
```

End ISD sizing controller 1

ISD sizing Controller 2

```
/dev/async/ctrl/spac(pci(0),D,0) 128.111.4.267 128.111.4.255 255.255.255.00 default
```

```
/dev/tty1030 128.111.4.267@4000 telnetin
/dev/tty1031 128.111.4.267@4000 telnetout
```

```
/dev/tty1500 128.111.4.267@4002 telnetin
/dev/tty1501 128.111.4.267@4002 telnetout
```

```
# End ISD sizing controller 2
```

"vtc.addr" file ended before this line.

Explanation of Entries:

Each controller **MUST** be assigned a unique Network portion of the IP address which is the first 16 bits of a Class B network number (128.222.0.0).

Example: 128.222.0.0 , 128.111.0.0 ... etc.

This IP network number, along with the node portion of the IP address (which is the remaining 16 bits of the 32 bit IP address structure) is used when assigning the lines you wish to test. See sample "vtc.addr" above, it contains a set of two pairs of lines to be tested per controller.

The following is the first line that appears in the vtc.addr file for each controller the user desires to test. It is essential that the vtc.addr file begins with the text " # ISD ". The test uses it as a start delimiter. The rest of the line, sizing Controller 1, is an optional comment.

```
# ISD sizing Controller 1
```

This line corresponds to the controller under test, along with it's IP address assignments.

```
/dev/async/ctrl/spac(pci(0),C,0) 128.222.4.267 128.222.4.255 255.255.255.00 default
```

This line corresponds to a single line set up. Each pair of lines use two protocols, telnetin and telnetout. Here, telnetin is used to set a line so that it will receive incoming messages. Telnetout is used to set a line so it can transmit messages to a telnetin line.

```
/dev/tty03 128.333.4.267@3000 protocol}
```

The final line has the end flag, it tells the test where the relevant text used by the test ends. " # End " is the critical text, the rest of the line is optional.

```
# End sizing Controller 1
```

6.4.2 Sync Test Requirements

The ix86 (Intel) PCI bus sync boards have an internal loopback mode that is integrated on the chip which the test enables via software. Older EISA cards will require an external loopback plug to be attached before executing the test.

(Note: Make sure X.25 daemon is not running prior to executing the sync test).

6.4.3 Async Loopback Plugs

RS232 Loopback Plug

<u>pin</u>	<u>sig</u>	<u>dir</u>		<u>Name</u>
2	TX	out	--+	Transmit
3	RX	in	<-+	Receive
4	RTS	out	--+	Request To Send
5	CTS	in	<-+	Clear To Send
6	DSR	in	<-+	Data Set Ready
8	DCD	in	<-+	Data Carrier Detect
20	DTR	out	--+	Data Terminal Ready

RS422 Loopback Plug

<u>pin</u>	<u>sig</u>	<u>dir</u>		<u>Name</u>
11	TX+	out	--+	Transmit +
9	RX+	in	<-+	Receive +
12	TX-	out	--+	Transmit -
10	RX-	in	<-+	Receive -
4	RTS	out	--+	Request To Send
5	CTS	in	<-+	Clear To Send
6	DSR	in	<-+	Data Set Ready
8	DCD	in	<-+	Data Carrier Detect
20	DTR	out	--+	Data Terminal Ready
13	sel	in	<-+	RS422 Select
7	gnd	out	--+	Signal Ground

6.4.4 Sync Loopback Plugs

This loopback plug applies to non-PCI cards only.

Synchronous Communications Loopback Plug

<u>pin</u>	<u>sig</u>	<u>dir</u>	<u>Name</u>
------------	------------	------------	-------------

2	TX	out	--+	transmit
3	RX	in	<-+	receive
4	RTS	out	--+	request to send
5	CTS	in	<-+	clear to send
6	DSR	in	<-+	data set ready
8	DCD	in	<-+	data carrier detect
20	DTR	out	--+	data terminal ready
17	RC	in	<-+	receive clock
24	XTC	out	--+	transmit clock out

6.5 Network Test Configuration

The purpose of this section is to describe some things to do prior to running the ISD Network Test.

The following list summarizes the test requirements:

At minimum a two controller network is established for sending and receiving test packets. For testing purposes, let's define the minimum network as the controller cables being connected to a hub. See Figure A. below.

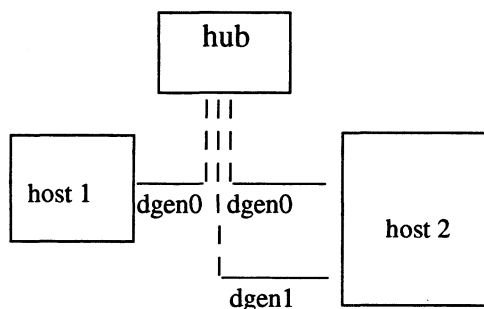

Figure A.

The Operating System is at init level 3 or 4.

The test can be run on one or all of the controllers.

6.6 Operating System Configuration Requirements

During OS installation or kernel build, an option is provided for configuring devices. When configuring the devices, the OS will assign conical names to the controllers. One way to determine the network names assigned to the controllers is to list the “/dev/net” directory:

```
#ls -l /dev/net
```

Additional setup procedures for networks are described in customer document 093-701051 “Managing TCP/IP on the DG/UX System”. The basic requirements are that each device be given a host name (e.g. host1, host2, host2-

alt,...) and IP address (e.g. 28.222.3.2). Once the host name and IP address are assigned, a network interface must be added. These operations can be done through the SysAdm interface.

a) To Add Hosts

Networking-> TCP/IP-> Databases-> Hosts-> Add

b) To Add a Standard Interface

Networking-> TCP/IP-> Interfaces-> Add

Note: IP addresses are regulated. Care should be taken when assigning addresses to devices that are directly or indirectly connected to external routers.

7. APPENDIX A

Changes to the ISD USER GUIDES.

Please disregard any previous descriptions of the Software Socket Test in your current user guides and refer to the following description instead.

7.1 Software Socket Test Exerciser.

7.1.1 Test overview

The socket test `isdsw_inet_sock` is designed to exercise the TCP protocol on a system's network interfaces which have been configured to run TCP/IP. This is done by setting up and testing client and server socket pairs on configured interfaces (which includes loop0). From a hardware point of view the exerciser communicates to itself via servers and clients through the interface, effectively implementing an internal loopback test strategy.

The test exerciser implements the connection-oriented type protocol available within TCP/IP through the Application Programming Interface. The client-server strategy is implemented in the socket test in the following way:

1. Size the system and determine the number of interfaces and CPU's.
2. Set the number of clients and servers each equal to the number of interfaces.
3. If the number of CPU's is greater than the number of interfaces set the number of clients and servers to be each equal to the number of CPU's up to a maximum of 16 clients and servers each.
4. The number of clients and servers is distributed on the interfaces as evenly as possible.
5. An address has two parts: a socket number and a network interface (IP) address.
6. A server chooses an address for the life of the test or until the individual server terminates and exits.
7. A client chooses an address for the duration of a connection.
8. A server socket must **bind** to an address: The server sockets in the test specify `INADDR_ANY` when binding; meaning that each server will accept a connection on any interface, if the system is multi-homed. After a **bind**, a server **listens** and subsequently **accepts** a connection request from a client.
9. A client socket does not (have to) **bind** to an address before it **connects** to a server socket. Rather it lets the **connect** call fill its local address. The client socket however does have to specify an address for the server it wants to **connect** to.
10. After a client **connect** request is successfully **accepted** by a server, a connection is established. The client and server sockets form the two ends of this connection. Now the client and server sides communicate by passing messages buffers. One end writes. The other end read and verifies.
11. After the communication ends, the client terminates the connection, closes his socket and establishes a new connection(issues a connect call).

7.1.2 Test Availability

The `isdsw_inet_sock` test is usually available in the list of selected tests which is run by default. The operator may prune this test from the list of selected tests through the select option.

Although the test is selected by default the test may be marked as unavailable for the following reasons:

1. There was a Memory Allocation failure in the sizer.
2. The system under test is not at init level 3 or 4.
3. The system does not have any network interfaces; or the available interfaces are not setup/configured to run the TCP/IP protocol.

An available and runnable socket test may exclude a (number) network interfaces(s) from testing; if these interface(s) are not configured to run TCP/IP.

ATM network devices if configured to run TCP/IP (Classical IP mode) export a ci or or li interface which will be included/tested by the Internet socket test.

7.1.3 Client Server Overview

The tests exercise each interface by establishing clients and servers on each interface and sending messages between themselves. All bytes in each message are verified by comparison internally by the test (outside of TCP). There is one test but several clients and servers based on the system's configuration. There is at least one client and server pair per interface. If the numbers of CPU's are greater than the number of interfaces then the number of CPU's determines the number of clients and servers. The clients and servers are distributed as evenly as possible between the interfaces in all cases. For example, on a 16 CPU machine there would be 32 clients and servers. If there were 4 interfaces each interface would have 4 clients and 4 servers. Thirty-two clients and servers is also the maximum allowed. A 32 CPU system could only have 32 clients and servers. The number of clients and servers and servers can be individually increased through prompting. The maximum for either is 16.

On the server side ports are selected at random but stay static throughout the test once ports are selected. See level two status #3 report. The client port is selected anew each transmission to the know server ports. This can be seen also in the level two status report #3.

7.1.4 Interface Overview

The number of interfaces tested are determined by the number of configured interfaces found. All interfaces found are tested when the isdsw_inet_sock test is selected. Clients and servers are distributed evenly through the interfaces, see Client Server Overview above.

7.1.5 Status Report, Level 0

Level 1 status gives a general look at the test and reports the total number of passes for all clients and servers on all interfaces.

Example:

```
In-Service Diagnostics release                Total Hard Errors: 0
Current Time: Sat Sep 13 20:06:06 1997      Elapsed Time: 1:35:28
TEST NAME          PASSES  HARD ERRORS  SOFT ERRORS  STATUS
isdsw_inet_sckt    548116    0            0            running
```

7.1.6 Status Report, Level 1

The level two options presented by the interface are listed below. Each is explained below with a sample of output.

- 1 isdsw_inet_sckt Subtest Summary
- 2 isdsw_inet_sckt Summary by Interface
- 3 isdsw_inet_sckt Snapshot servers/client

1 isdsw_inet_sckt Subtest Summary

This report gives a general view of the test by reporting on the only subtest which runs the tcpip_subt. The report is self explanatory.

```
Level 1 status for isdsw_inet_sckt          Total Hard Errors: 0
Current Time: Sat Sep 13 20:18:37 1997      Elapsed Time: 1:47:59
Test is running
```

SUBTEST NAME	PASSES	HARD ERRORS	SOFT ERRORS	MBYTES WRITTEN	MBYTES READ
tcpip_subt	619875	0	0	3358	3358

2 isdsw_inet_sckt Summary by Interface

The level 1 status presents the interfaces seen and its IP address. For each interface the bytes which were written then read back and verified as sent correctly are given under the heading BYTES READ WRITTEN.

Level 1 status for isdsw_inet_sckt Total Hard Errors: 0
 Current Time: Sat Sep 13 20:23:04 1997 Elapsed Time: 1:52:26
 Test is running
 Summary by Interface

INTERFACE	IP ADDRESS	MBYTES READ WRITTEN	BYTES THIS PASS
dpen2	199.1.4.1	1888	7809
dpen3	199.1.2.1	1762	9804
dpen0	199.1.1.1	1309	7882
dpgn0	199.2.1.1	1493	3594
ci0	199.4.2.1	1590	4857
dpen1	128.221.223.154	1448	5898
loop0	127.0.0.1	1743	4786

3 isdsw_inet_sckt Snapshot servers/client

The third level two test report gives a snapshot of the ports and interfaces i.e. a fleeting capture. By the time the capture starts versus when it finishes the ports may have changed so is unreliable. The view does give an idea of what interface and port is being exercised at the moment. On the server side the ports are chosen at random by the test but once chosen are static. The server ports reported in this view do not change. The server interface is selected internally by the programming choice of INADDR_ANY i.e. use any available so the name and address reported is Any for Name and Address. The connect count indicates how many client are currently connected at the time of the snapshot. It is not a reliable view but this field over time will have a count so a port which never has a count indicates a problem. On the client side the current Port, Address and Interface in use at the time of the snapshot is provided. Not all clients may be active at the time of the snapshot and this is indicated by Interface name set to NULL. A -1 for port also indicates inactivity. The status report below is for an 8 CPU system with 4 interfaces. Only a few of the clients and servers are shown but are indicative of what is reported in an actual report.

Level 1 status for isdsw_inet_sckt Total Hard Errors: 0
 Current Time: Sat Sep 13 20:24:56 1997 Elapsed Time: 1:54:18
 Test is running
 Snapshot servers/client

SUBTEST NUMBER: 0

Info for Server # 0

Port 6578
 Connect Count 2
 Interface ANY
 IP Address ANY

.....

Inf. for Server # 5

Port 6736
 Connect Count 1
 Interface ANY
 IP Address ANY

Info for Server # 6

Port 6894
 Connect Count 1
 Interface ANY
 IP Address ANY

Info for Server # 7

Port 6634
 Connect Count 2
 Interface ANY
 IP Address ANY

Info for Client # 0

Port -1
 Interface NULL
 IP Address NULL

Info for Client # 5

Port 1994
 Interface dpen1
 IP Address 128.221.223.154

NOTE: ANY indicates any interface may be used.

NULL indicates currently not active.

-1 indicates port not assigned.

7.1.7 Status Report, Level 2

The level two status presents another snapshot view of the clients and servers. The Accept/Connect errors applies to both the servers and clients and is set on the first hard error. The re-tries sections apply only to clients connecting and retrying to servers and are listed to indicate problems. If the number of retries are of some value other than zero often or all the time (often being subjective depending on configuration and load). The problem could be with software or hardware but more likely indicates a busy system. The bytes read and written are counts only of a single transmission and are not accumulated (they cannot be accumulated on a client server basis as connections are changing). The view is unreliable since the system is running. A capture may start with client/servers 1 and 6 active but by the time the test gets loops to client server four, six finishes and five starts etc. Six would not be reported and five may be depending on timing. So the view is unreliable over the short haul but can be used as a sort of histogram to monitor behavior. For example, the report could indicate an interface being favored where it can be seen over time that one server always has Accept/Connect errors or a particular client is dropping bytes.

Current Time: Sat Sep 13 20:53:29 1997 Elapsed Time: 2:22:51

Level 2 status for isdsw_inet_sckt tcpip_subt subtest

Test is running, subtest is unblocked

Server # 0

Accept/Connect errors 0
 Server, Bytes write 2144
 Interface ANY
 IP Address ANY
 Socket Type TCP

Server # 1

Accept/Connect errors 0
 Server, Bytes write 9692
 Interface ANY
 IP Address ANY
 Socket Type TCP

Client # 3

Choose Server Re-tries 0
 Accept/Connect Re-tries 0
 Accept/Connect errors 0
 Client Bytes read 2144
 Interface Name dpfn0
 Address 199.2.1.1

Socket Type	TCP
Client # 4	
Choose Server Re-tries	0
Accept/Connect Re-tries	0
Accept/Connect errors	0
Client Bytes read	8412
Interface Name	ci0
Address	199.4.2.1

NOTE: ANY indicates any interface may be used

End of Release Notice



(P) Part Number:

085001571

(2P) Revision:

00

(Q) Qty:

1